

Home Maintenance & Care

Content

DISCLAIMER	5
STRUCTURAL SYSTEMS	5
SITE SAFETY	5
FOUNDATIONS.....	5
SOIL COMPOSITION	5
FOUNDATION WATERING PROGRAM.....	6
TREES AND SHRUBS.....	6
CONCRETE SLAB-ON-GRADE.....	6
PIER AND BEAM	6
GRADING & DRAINAGE.....	7
ROOF COVERING.....	8
ROOF SURFACES	8
OVERHANGING TREES	9
FLASHING	9
SKYLIGHTS.....	9
ROOF STRUCTURES & ATTIC	10
STRUCTURE AND FRAMING IN THE ATTIC.....	10
VENTILATION	10
RAIN GUTTERS AND DOWNSPOUTS.....	10
INSULATION	11
WALL (INTERIOR & EXTERIOR)	11
INTERIOR WALLS.....	11
CAULKING	11
CONDENSATION	11
EXTERIOR WALLS.....	12
BRICKS	12
CONCRETE.....	13
LANDSCAPING.....	13
CEILINGS & FLOORS.....	13
CEILINGS	13
FLOORS.....	13
DOORS (INTERIOR & EXTERIOR).....	14
WINDOWS.....	15
WINDOW SCREENS	15
FIREPLACE / CHIMNEY	16
FIREPLACE SAFETY	17
PORCHES,DECKS&CARPORTS	18
ELETRICAL SYSTEMS.....	18
SERVICE ENTRANCE & PANELS	18

EXTERIOR ELECTRICAL CONNECTIONS.....	19
SERVICE PANEL BOX (BREAKER BOX).....	19
ALUMINUM WIRING.....	19
BRANCH CIRCUITS.....	19
GROUND FAULT PROTECTION (GFCI'S).....	19
CEILING FAN.....	20
SMOKE DETECTORS.....	20
CARBON MONOXIDE DETECTORS.....	20
FIRE EXTINGUISHERS.....	20
HEATING, VENTILATION AND AIR CONDITIONING SYSTEMS	21
HEATING EQUIPMENT	21
THERMOSTATS AND CONTROLS.....	21
COOLING EQUIPMENT	21
DUCTS & VENTS	22
RETURN AIRFILTERS.....	22
HVAC DUCTWORK.....	22
PLUMBING SYSTEM	23
WATER SUPPLY SYSTEM FIXTURES	23
WATER METER.....	23
EXTERIOR PLUMBING.....	23
CRAWL SPACE PLUMBING (PIER & BEAM HOMES).....	23
INTERIOR PLUMBING.....	23
CLOGGED DRAINAGE LINES.....	24
PLUMBING FIXTURE CARE.....	25
IMPORTANT NOTICE FOR COLD WEATHER!.....	26
WATER HEATING EQUIPMENT	26
GAS WATER HEATER.....	27

HYDRO-THERAPY EQUIPMENT	27
APPLIANCES	28
DISHWASHER.	28
FOOD WASTE DISPOSER	29
JAMMED DISPOSER	29
DISPOSER DO'S AND DON'TS	29
RANGE HOOD	30
RANGE / OVEN / COOKTOPS.....	30
MICROWAVE COOKING EQUIPMENT	31
BATHROOM EXHAUST FANS AND HEATERS	32
BATHROOM EXHAUST FANS	32
BATHROOM HEATERS.....	32
GARAGE DOOR OPERATORS	32
DRYER VENTS	33
OPTIONAL SYSTEMS	33
LAWN SPRINKLERS	33
SWIMMING POOLS AND EQUIPMENT	33
GAS LINES	35
WATER WELLS	35
RADON IN THE HOME.....	37
TERMITES	38

TERMITE CONTROL	38
MOISTURE PROBLEMS IN THE HOME	39
HIGH HUMIDITY LEVEL PROBLEMS	39
SUMMER PROBLEMS	39
HOUSES ON CRAWL SPACES	39
ATTIC VENTILATION	39
CAUSES OF MILDEW	40
PREVENTING MILDEW	40

Disclaimer

Note to home owners and home buyers: The information found within is general in nature as this manual is a work in progress, the information here in, by definition, is incomplete. Since conditions and requirements vary widely at individual sites, it is recommended to obtain qualified expert advice pertaining to the specific system about which you have a question, and should not rely on this general text for costly diagnostic/repair/replacement decisions.

All homes, brand new or aged, require ongoing maintenance and repair. *This home is no exception.* Electrical and mechanical systems will fail without warning, crawl spaces will likely develop water penetration problems, roofs often develop leaks as they age, exterior siding and wood trim will decay and require periodic repair and repainting. Homes are, by their very nature, a series of complex systems, all of which have finite lives and are susceptible to unexpected failure!!

Warning; All do-it-yourself home maintenance activities involve an element of risk to your health and safety as well as to your property. We have made every effort to assure that the content of this booklet outlines safe procedures. However you, as the homeowner, remain responsible for performing home maintenance activities in a safe and secure manner. When using hand and power tools, ladders and other equipment always follow the manufactures operating instruction and observe all safety precautions.

There's nothing like the excitement of moving into a brand new home! And like other major tangible investments, you will want to take excellent care of your home - so all its working parts operate smoothly, and so it will keep that new home "feel" for many years to come. As a way of helping you do just that, we have compiled this section on home maintenance and care. We hope you will find it helpful.

STRUCTURAL SYSTEMS

IN THE YARD

Site Safety

Periodically walk around the yard with an eye to safety. Have holes dug by dogs, which might trip someone, filled with soil. Are sidewalks and driveways free of clutter and tripping hazards, like raised edges? Are covers for water meters or lawn sprinkler control boxes properly installed? Look for low hanging branches, wires or other hazards. Corrective action now, may prevent grief later.

Gather old or unused paints, insecticides, toxic cleaners and depleted household batteries for hazardous waste pickup or delivery to an approved disposal site.

Foundations

Soil Composition

Highly plastic clay soils, as are typically found in this region, exhibit a great amount of expansion and contraction with varying moisture contents. Clay soils that become too dry will shrink and will not be able to physically maintain the elevation of a structure's foundation. Conversely, clay soils that become over-saturated can easily lose their load bearing capacity.

Various factors control the moisture contents of clay soils. Probably the most significant of these is the seasonal moisture changes which occur as a result of varying weather conditions. Soil exsiccation as a result of the hot, dry summer months can have a devastating effect on structural foundations in this region. High ambient temperatures, in conjunction with long periods of inadequate rainfall, can cause moisture loss in soils up to several feet below the surface. This moisture loss is compounded when trees or bushes, which actively consume water from both the surface soils, are located in close proximity to a building's foundation.

FOR A SOLID FOUNDATION

Foundation Watering Program

Very Important

Keep an eye on the soil conditions around your house. One way to tell if the soil is too dry is to examine the “soil line” at the perimeter of the house. If the soil line (where the soil meets the concrete beam) has pulled away from the foundation more than 1/8” it is time to water. Ideally, the soil should be kept moist enough so that it is continuously snug against the concrete beam wall. NOTE: If you find that the soil has pulled away from the beam wall more than this amount, do NOT add water directly INTO the separation! If water is put directly into the soil line separation, it may settle at the bottom of the concrete beam wall and make the soil in that area TOO WET to adequately support the wall. Instead, water the area “just as a rainstorm would” with a sprinkler system or soaker hose. The separation should close by itself in a few days.

Water the foundation in a uniform, systematic manner. Use of an automatic sprinkler system and/or soaker hoses (placed about 18 inches from the perimeter beam wall) are effective watering methods if used correctly and regularly. The key is to keep the soil around the perimeter of the house moist, but not muddy. As a general rule, watering every day for about 20 minutes is usually sufficient. Please note, that substantially MORE watering of the foundation may be required during very hot, dry periods.

Trees and Shrubs

Do not plant trees and bushes next to the foundation. Trees in particular should be planted no closer to the foundation than their expected mature height (i.e. if a tree is anticipated to grow to a height of 30 feet, it should be planted at least 30 feet away from the house.) Certain fast growing bushes (e.g. red tipped photenias) should be avoided completely if possible. Keep in mind that the reason these bushes grow so fast is because they consume large amounts of water!

Trees should be planted far enough away from the house that their canopy would not overhang the roof when they are fully mature. A tree’s root system mimics its canopy. Roots growing under a foundation can destabilize it in several ways for instance, by removing moisture from the soil that a foundation needs for its structural support.

When trees are close to the house, their limbs should never touch the building, or serious damage can result. Be aware, too, that growing root systems can lift sidewalks, patios and driveways, causing damage and creating trip hazards.

Concrete Slab-on-Grade

Foundation walls are usually made of poured concrete. Foundation walls are subject to a wide variety of stress and strain. Combined stress and temperature variations may cause cracks in the foundation walls. Walk around the house studying the edges of the foundation. Look for cracks in the edges or soil separation from the edge of the slab and unusual discoloration or water stains, mud or mounded dirt piles on the slab edge.

Cracks in the foundation edge may indicate foundation movement or settling. Some cracks are not unusual and may not be structurally significant, but if in doubt, have a qualified structural engineer or other expert evaluate them. Discoloration and/or water stains can indicate a plumbing leak in the house and should be further evaluated, but if in doubt, have it evaluated by a qualified plumber. Mud or mounded dirt piles on slab edges may indicate destructive or hazardous insects invading the house. Again, call an expert or qualified pest control operator.

Pier and Beam

Foundation walls are usually made of poured concrete, masonry blocks or wood framing. Walk around the perimeter of the house looking for cracks or damage to the crawl space skirting and ventilation openings. Skirting and vent screens should be kept in good condition to prevent animal access and to maintain adequate ventilation year-round. Inadequate venting or blocked vents can lead to moisture build-up under the house, fostering wood rot and wood-destroying insects. Proper crawl space ventilation is calculated at one (1) square foot of free vent area should be provided for every one hundred and fifty (150) square feet of crawl space. Proper ventilation will help to control humidity and reduce the potential for rot. Crawl spaces should be vented to the building exterior.

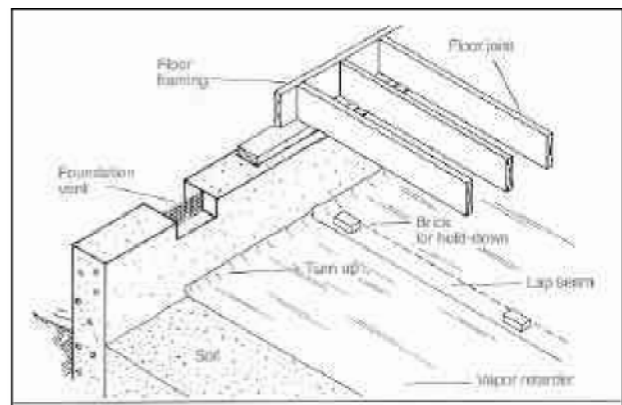

One exception to the ventilation calculation of 1/150 square feet can be made. The total area of ventilation opening can be permitted to be reduced to one (1) square foot of free vent area for every one-thousand five hundred (1,500) of under-floor area, when the ground surface is treated with an approved vapor barrier material and one such ventilation opening is within three (3) feet of each corner of the building.

An annual inspection of the crawl space is best left to a qualified inspector. If you must do it yourself, follow these safety tips. Always let someone know where you will be, wear sturdy coveralls and a dust mask, carry a bright light and avoid contact with any electrical wiring. The crawl space should be clean and dry. Nothing should ever be stored in the crawl space. Before entering the crawl space, turn the interior water fixtures on at the sink/lavatories, tubs, and showers and flush each commode/toilet at least twice. (**CAUTION: NEVER ENTER A CRAWL SPACE WITH STANDING WATER.**) While under the house, look for evidence of animal and insect infestation, leaking plumbing, foundation movement and anything else unusual like damp or rotted wood in bath and kitchen areas. After completing your inspection, be sure that the access hatch cover is in good repair, fits the opening properly and is securely closed.

Grading & Drainage

Do not allow water to stand near your homes foundation.

Is your property on a hillside that directs water runoff towards the house, or is your lot basically flat? Your goal is to have rain drain off the lot promptly without ponding within ten feet of the house.

Remember that good drainage is just as important as proper foundation watering. Clay soils that are too wet will exhibit liquid characteristics and will lose their load-bearing capacity. To ensure proper drainage, soils around the perimeter should have a positive slope away from the house. Lots should be graded so as to drain surface water away from the foundation walls. The grade away from foundation walls should fall a minimum of six inches (6") within the first ten feet (10ft.). If adding soil to the perimeter to create positive drainage, remember to keep the soil level about two (2) inches BELOW the foundations brick ledge. In addition, only clayey soils should be placed around the perimeter. Porous, sandy soils should be avoided.

Solutions to drainage problems are as varied as the terrain, and may include rain gutters and gutter extensions, French drains, swales and barns, retaining walls, catch basins and even sump pumps. With a little planning and some work, almost any yard can provide a healthy environment for a stable foundation, a dry house, and control of mosquitoes.

In many cases, a drainage swale is the most economical of corrections.

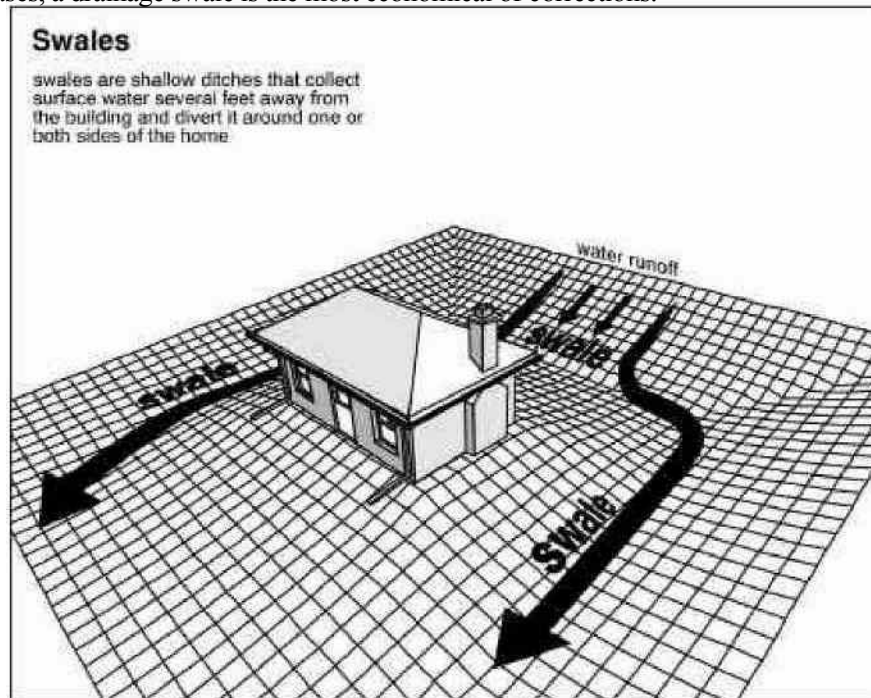

Roof Covering

Safety Note: Falling from a roof can be hazardous to your health! Do not get on a roof unless you are completely comfortable, have the proper equipment for access, and wear appropriate clothing-including rubber-soled shoes. If you have any doubts, ask a qualified roofing contractor or inspector to check the roof. Most roof repairs are best left to a qualified roofing contractor.

Roof Surfaces

Composition shingle roofs look for signs of damage or wear. Sweep off leaves and debris.

Worn surfaces, missing granular coating, cracked, pitted, brittle or swollen shingles are signs that shingles may be nearing the end of their useful life. Raised shingle tabs may indicate improperly seated fasteners that can be fully

reseated; take care not to tear the shingle or poke a hole in it. Split, torn or missing shingles may cause leaks and should be replaced immediately. While on the roof, also check the condition of side walls not visible from the ground.

Wood roofing material can be White Cypress, Western Red Cedar, Northern White Cedar, Red Wood, White Pine, and White Oak. The Texas area uses predominantly Cedar. Cedar roofing can be either a shake or shingle. Shakes are distinguished from shingle by their rough, non-uniformed appearance. In order to extend the service life of the Cedar roof, we suggest the following: Keep pine needles, leaves, and other organic debris off of the roof. These things trap moisture and encourage rot causing moss and fungus. Use a regular chemical cleaner. One such formula recommended by the Forest Service is a 10% solution of Copper-8 (Copper Quinololate) in water. This solution is non-toxic to vegetation and animals.

Wear eye and skin protection when applying. **Note:** Oils and preservatives are controversial because they are expensive and not proven to extend the roof's life, and rapidly leaches out of the wood.

Flat or built-up roofs may be surfaced with several different types of roofing materials. Generally, check for areas of water ponding, areas of missing aggregate coverings or gravel, tears or blisters in the surface and deep alligator cracking. Also check the condition of flashing at edges and vents. Flat roofs are prone to leak and require regular maintenance; therefore a qualified roofing contractor should further investigate any such problems. Leaves and debris left on the roof will hold water and speed deterioration.

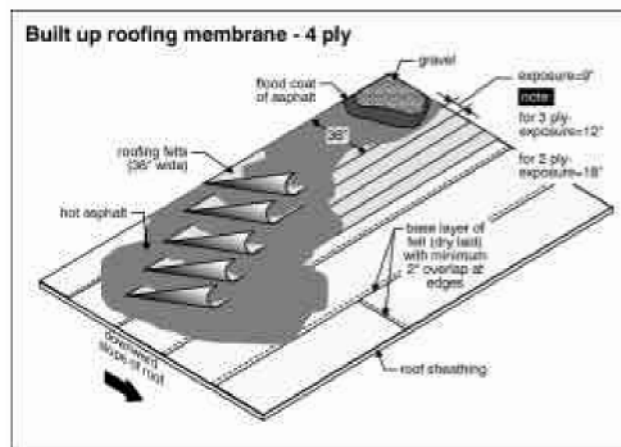
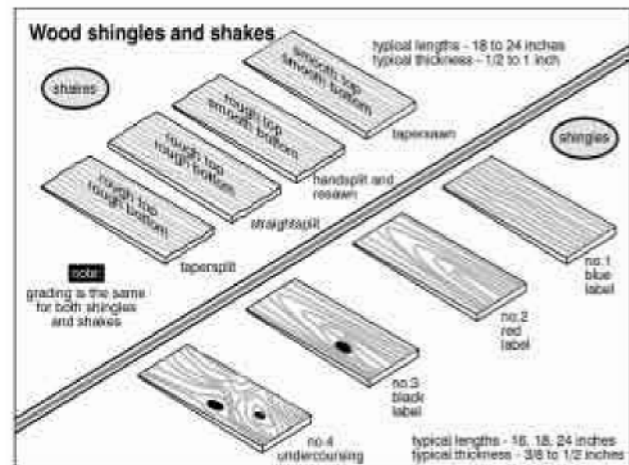
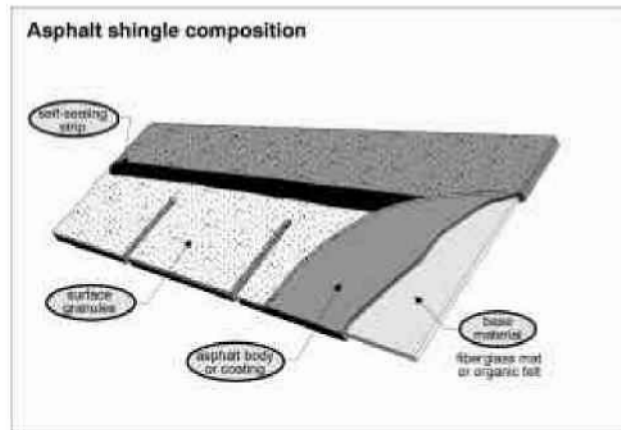

Concrete and clay tile roofs are easily damaged, and a thorough inspection is best left to a qualified roofing contractor. Walking on a tile roof is not recommended. From eaves you can check the general roof condition. Look for rotted fascia, loose/missing or cracked tiles, deteriorated caulking and sealant.

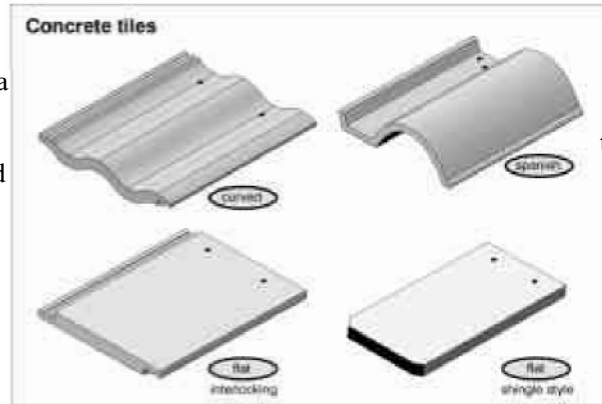

Metal roofs are best observed from a ladder at the eaves. Walking on a metal roof can bend panels, creating leaks. Look for loose fasteners, rusted panels, open seams, bent flashing and deteriorated caulking. Leaves and debris should be removed from roof surfaces.

Composition Shingles Only:

After you have been in your home for four or five years, you may notice a little mildew or mold on your shingles. This can easily be cleaned with one of the following:

Pool Shock (used to kill algae in swimming pools) or a mixture of:

- 1/2 gallon of Clorox
- 1/2 gallon of warm water
- 1 cup of Tide

(This mixture can be increased in like proportions.)

Either of these mixtures can be applied to the roof and swept down with a broom. Note that either of these mixtures will kill grass and plants near the house if spilled on them. Take precautions to protect your landscape. Also remember these solutions may be caustic to any exposed skin. We suggest you wear gloves and appropriate clothing.

Overhanging Trees

Tree limbs rubbing on a roof can do serious damage. Overhanging branches should be kept trimmed to provide adequate clearance even in a high wind, and to prevent insect infestation. Standard rule of thumb is that if standing on the roof and you can touch the tree branch, it is to close. Trees can grow rapidly and should be inspected at least twice a year. Oak wilt is a serious problem in many areas of Texas and can best be prevented by trimming oaks during the coldest or hottest times of year. Sterilize pruning tools with bleach, and promptly cover cuts with wound paint. Major trimming is best left to a certified arborist.

Flashing

Most roof leaks occur around flashing. Metal flashing at the chimney, in roof valleys, at side walls, skylights and vents should be in good condition, not rusted or bent. They should lay flat on the roofing surface, laced in the roof covering "shingle style." Do not nail down raised flashing. The nail puts a hole in the roof allowing water penetration.

Skylights

It is advisable to inspect your skylights on the inside and outside as part of the routine maintenance of your home. Skylights might leak if there is a break in the seal. Keep the seals caulked and inspect the seals and flashing around your skylight on a regular basis.

Roof Structures & Attic

Structure and Framing in the Attic

Note: Attic inspections are best conducted during cool weather or early in the morning. If you expect to spend more than a few minutes in the attic, a dust mask is recommended. Exercise extreme care to step only on solid decking or framing members. Falling through the ceiling could ruin your day!

Check roof framing for loose members and separation or gaps where rafters connect to ridge boards. Also be sure metal truss plates are not twisted or loose. Excessive evidence of movement could suggest foundation problems and should be inspected by a qualified structural engineer. The underside of roof decking should be dry and free of water stains and mildew caused by leaks. Valleys deserve special attention.

Be sure that attic vent pipes from bathrooms, the kitchen range hood and the clothes dryer are intact and direct moisture and fumes through the roof to the outside. In some older homes, bathroom vents and the kitchen range hood were terminated in the attic. This is unsafe and no longer considered acceptable. Consider extending these vents through the roof. A good time to do this is when the roof surface is replaced.

Torn or missing soffit vent screens allow birds and other critters into the attic; they should be repaired or replaced. Consider calling an exterminator if you find rodent droppings, nesting materials or other evidence of critters.

Ventilation

Good ventilation removes moisture and heat from the attic, contributing to a healthy house. Check that your attic is adequately ventilated and that all vent screens are in good condition. To check soffit vents, stand in the center of a dark attic and look for light at the edges. No visible light may indicate soffit vents are blocked by insulation. Proper attic ventilation is calculated at one (1) square foot of free vent area be provided for every one-hundred and fifty (150) square feet of ceiling area. Proper ventilation will help to keep the house cooler during warm weather and extend the life of the roofing materials. In colder climates, it will help reduce the potential for ice dams on the roof and condensation within the attic area.

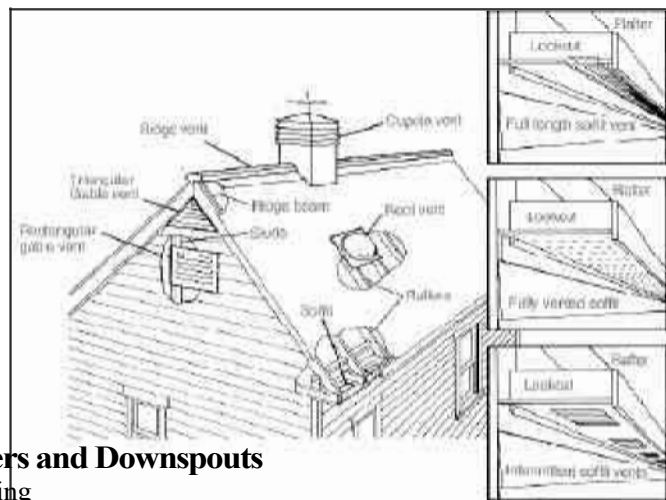

Rain Gutters and Downspouts

If you don't have rain gutters, consider adding them. Properly installed gutters can help solve drainage problems and promote foundation health.

Clean rain gutters and downspouts as needed to keep them flowing freely. In an area of heavy trees, cleaning may be required several times a year. Consider the addition of gutter guards to reduce maintenance. Inspect gutters for proper drainage (standing water can breed mosquitoes and carpenter ants), leaks at seams or end caps, loose or missing gutter spikes and loose or missing downspouts. Look behind gutters for rotted fascia, and repair as needed. Splash blocks or downspout extensions should direct water into the yard well away from the foundation.

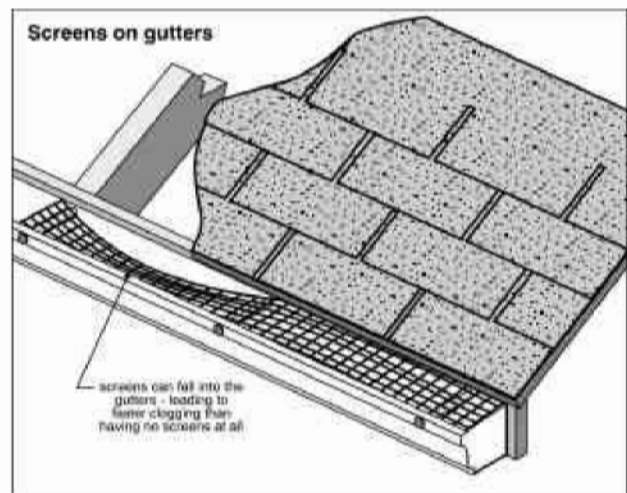

Insulation

Adequate attic insulation helps keep your home comfortable and lowers heating and cooling costs. Look at the insulation in your attic spaces and consider adding insulation if yours is skimpy, compacted or unevenly distributed. Consult an insulation specialist to determine what is recommended in your area.

RECOMMENDED INSULATION VALUES FOR HOMES

(Based on Climate and Estimated Fuel Costs)

Optimum R-Value

(Wall/Ceiling)

Location	Electric heat @ rate of: 8cents/KWH	10cents/KWH	Gas heat @ rate of: 50cents/ccf	80cents/ccf
Dallas/Ft. Worth,	R22/R30	R25/R34	R19/R27	R23/R31

Wall (Interior & Exterior)

Interior Walls

Periodically, you should touch up any hairline settling cracks in your sheetrock corners. The same type of cracks occur in the wood joints around your doors, and are due to normal settling of your house. These can be taken care of easily with a good quality latex caulking and latex or enamel paint.

Whenever you are doing paint maintenance or repair on your walls, paint a small test patch on your wall and let it dry to make sure it matches. Wall paint will sometimes discolor from smoke, sunlight, etc., so it is sometimes necessary to paint a larger area than the immediate repair. If paint starts to blister or peel, repaint or touch up immediately to prevent spreading.

Your house has two types of walls, bearing and non-bearing. All exterior walls are bearing walls and in some structures, some of the interior wall can also be load bearing. Only non-bearing walls may be altered without fear of structural damage. All ceilings are essentially the same in structure, but they are made of a variety of materials.

Minor cracks may appear in the plaster from time to time, but they can be repaired easily. To repair, fill the crack(s) with spackling compound, smooth it with fine sandpaper, then redecorate the entire surface. To prevent cracks wider than a half an inch from reopening, apply the spackling compound, then cover the crack with a strip of fiberglass mesh made for this purpose. Next, cover the mesh with another thin layer of spackling compound and sand smooth. Finally, repaint or redecorate the repaired area. **Note:** Some cracks are not unusual and may not be structurally significant. If you are finding wall cracks greater than 1/8 of an inch, you should have qualified structural engineer or other expert evaluate them.

Normal shrinking will cause nails to pop from wallboard. Popped nails do not alter the strength of the wall and they can be left alone until you redecorate. They should then be reset, re-spackled, and repainted.

Caulking

Time and weather will shrink caulking and dry it out so that it no longer provides a good seal against moisture and air filtration. As a matter of routine maintenance, you should check the caulking both inside and outside your home and make the necessary repairs. These areas would include the window frames, wood trim where it meets brick, wood trim inside at floors and around doors, shower and tub tile, counter tops in kitchen and baths. There are a number of different types of caulking available for different areas and applications around your home. Generally, a silicone or acrylic caulking should be used on exterior surfaces, while a latex caulk should be used inside. Colored caulks are also available for those areas that cannot be easily painted.

Condensation

Condensation is a sign of excess humidity inside your home and is more likely to exist during the cold weather months. The amount of condensation usually depends on how much moisture is contained in your home's air and how much of that moisture is ventilated to the outdoors.

If you see condensation on the windows, it is a sign that excess moisture could also be collecting in unseen places in your home. In serious cases it could damage the wall paper or drywall. This excessive moisture may be freezing in the insulation in your attic where it will melt and damage your ceiling when warm weather comes (exactly like a roof leak). Or it may be forcing its way out through siding to form blisters under your exterior paint. It's natural and easy to blame the paint or insulation, or the windows but it's wrong to blame them. The real villain is invisible. It's water vapor.

What causes indoor moisture? Daily activities such as cooking, doing laundry, taking showers, and washing dishes all add moisture to the air inside a home. Even the normal perspiration and breathing of a family of four add about half a pint of water to the air every hour. All this moisture builds up if not released to the outside somehow. This is more of a problem in winter, when houses are tightly sealed against the elements, and when there is a greater temperature differential between inside and outside air. Some causes of condensation are temporary and will disappear after a few weeks, or at most after a season of heating.

Today's energy efficient new homes are being carefully designed to seal out cold air. In addition to having insulated, watertight windows and doors, they also have efficient weather stripping, heavy insulation, and may use special vapor barriers to make them airtight. After new construction is completed, condensation may be noticed. There is quite a lot of moisture in the wood, plaster and other building materials used in construction. When the heating season starts, this moisture will then flow out into the air inside the home. Generally, it will disappear after a few months.

Reducing indoor humidity during winter months can eliminate excessive condensation throughout your home. By maintaining adequate ventilation and humidity control you can minimize excessive condensation during the cold months.

There are several ways to reduce or eliminate excess humidity and condensation inside your home. A temporary solution is to open a window in each room for just a few minutes. This is especially helpful after showering or using the washing machine. Keep the attic louvers open. This allows moisture that travels upward through the house and into the attic to be released to the outside. If you have exhaust fans in your kitchen, bathrooms and utility rooms run them longer than usual in winter. Keep draperies and shades open so that air can circulate around the inside glass. Eliminate any other controllable sources of moisture in your house. Properly ventilate clothes dryers and all gas appliances.

AROUND THE OUTSIDE

Exterior Walls

Four inches clearance from finished grade to masonry type sidings and six inches clearance from finished grade to all others is recommended to minimize moisture damage and insect infestation. If soil is graded to improve siding clearance, take care that water does not pond at the foundation edge (see "Grading & Drainage").

Exterior surface should be checked for fading, chalking, blistered or flaking paint; rusted fasteners and "nail pops"; loose or rotted wood, panels and trim; gaps between panels, and water damage. Masonite, hardboard and other composite panels are prone to "nail pops" and water damage at edges and bottoms, and should be kept well painted and dry. Remember to thoroughly paint the bottom edge of these panels, for greatest protection. Loose fasteners can be replaced with large-headed screws (with washers if necessary) for a more permanent repair. Gaps or cracks at trim or between panels should be sealed with a good quality exterior caulk. When repainting exterior surfaces, pay special attention to surface repair and preparation so your paint job will last.

Masonry walls should be inspected for soft or missing mortar, cracks or separations in mortar joints and cracked or loose bricks or stones. A competent mason can replace soft or missing mortar. Cracked masonry or mortar joints may indicate foundation distress and should be inspected by a qualified structural engineer who can recommend any needed repairs or remedial action. Weep holes are openings in the bottom of brick or stone walls and above window and door lintels designed to allow an escape route for moisture that enters the wall cavity. Weep holes are usually spaced about four feet apart and should not be obstructed.

Carefully inspect stucco surfaces for cracks and evidence of moisture penetration. Stucco is often installed without provision for moisture to escape from wall cavities. Moisture seeping through cracks can do serious damage before detection. If repairs are needed, it is always recommended that a professional familiar with stucco exterior surface do the repairs. Stucco siding should terminate several inches above the soil.

Bricks

The exterior bricks are a very important part of your home's cosmetic appeal. Dirt or sand should be washed off the brick periodically with a low-pressure water hose. Some bricks will develop a lime deposit (white color) that can be easily cleaned with baking soda and water.

Also, when adding flowerbeds or other landscaping, be careful not to block the weep holes located along the bottom course of bricks. These weep holes should be cleaned out from time to time, since they are essential for draining moisture absorbed by the brick.

When watering your lawn or flowerbeds, be careful not to spray directly into the weep holes. Water may seep into the living areas, causing wet carpet, or buckled/mildewed vinyl.

Concrete

With time, you may notice cracks appearing in your concrete driveway and sidewalks. These cracks are the result of expansion and contraction due to temperature changes as well as the natural shrinkage of the concrete as it “sets up” to full strength. These types of cracks cannot be prevented and do not affect the structural integrity of the concrete

Landscaping

Remove or thin dense foliage close to the house to allow for inspection of exterior surfaces and good air circulation. The foliage holds moisture, promotes rot and damages all siding types. To minimize wood rot and insect damage in siding and trim, allow air to freely circulate next to the house. This is easily accomplished by locating decorative plants several feet away from exterior walls and keeping them trimmed off the exterior walls at least 8-inches. If siding is easily visible, maintenance problems will be detected early and unwanted guests (insects) will not have a place to hide. Vines should not be allowed to grow on or cover walls. Vines growing on any exterior surface will cause serious damage over time and should not be permitted. Do not try to remove vines by pulling them off. Instead, sever them at the ground and wait until the plants have died before removing them.

Landscaping not only increases the value and attractiveness of your home and neighborhood; it also serves a practical purpose. Shade trees, properly placed, will help you conserve energy by reducing the amount of heat coming into your home. Flower beds around your home will ensure an even moisture content and reduce the effects of settling, especially in the dry summer months; the ground “shrinks” away from the foundation.

When you do add flowerbeds, trees, etc., be sure to note how the yard is designed to drain. Be careful not to alter this grading since it could result in problems with standing water in your yard. With time, some settling and/or ground erosion will occur and it is possible that you might have some areas where water stands. If the water does not drain within a 48-hour period, these areas should be filled.

Ceilings & Floors

Ceilings

Minor cracks may appear in the plaster from time to time, but they can be repaired easily. To repair, fill the crack(s) with spackling compound, smooth it with fine sandpaper, then redecorate the entire surface. To prevent cracks wider than a half an inch from reopening, apply the spackling compound, then cover the crack with a strip of fiberglass mesh made for this purpose. Next, cover the mesh with another thin layer of spackling compound and sand smooth. Finally, repaint or redecorate the repaired area. **Note:** Some cracks are not unusual and may not be structurally significant. If you are finding ceiling cracks greater than 1/8 of an inch, you should have a qualified structural engineer or other expert evaluate them.

Normal shrinking will cause nails to pop from wallboard. Popped nails do not alter the strength of the ceiling and they can be left alone until you redecorate. They should then be reset, re-spackled, and repainted.

Floors

Floors are usually made of either concrete or wood but may be covered by a wide variety of materials.

Concrete Floors are generally maintenance free, but they are susceptible to cracking under unusual conditions. A concrete sealer will make an unpainted concrete floor easier to keep clean. Unpainted concrete floors should be cleaned with a solution of 4 to 6 tablespoons of detergent to a gallon of hot water. First wet the floor with clear water. If necessary, scouring powder may be used in conjunction with the detergent solution. A stiff brush will help to loosen dirt. Rinse with clear water. Painted concrete floors can be cleaned with plain water or a mild soap or detergent solution.

Carpet – Care for your carpet with regular vacuuming using a vacuum cleaner equipped with a beater bar and adjusted to the proper height. New carpet will shed somewhat the first few times it is vacuumed. Your carpet can easily be spot cleaned with a commercial rug-cleaning product. Follow manufacturer’s label and test a small area before you proceed with cleaning the entire area.

Hardwood Floors may contract or expand with weather changes. Normal maintenance should include regular vacuuming or dry mopping to remove surface dirt and dust. If your hardwood floor is excessively soiled, it can be cleaned with mineral spirits or commercial cleaners, some which leave a protective coat of wax as they clean. Do not use water to clean hardwood floors. Water sometimes causes the grain to swell, and prolonged use may cause cracks from the swelling and shrinkage of the wood. Protect the finish on wood floors by attaching furniture rests to the bottom of furniture legs. They also help to distribute the weight better.

Vinyl – Occasionally wipe resilient floors with a damp mop. For daily care, remove loose dirt with a broom, dust mop, or vacuum. Some vinyl floors are designed to never need waxing, but most of them retain their beauty better with the occasional application of polish designed for today’s “easy care” floors. Follow the manufacturer’s recommendation.

Tile Floors – Normally need only a wipe with a damp cloth or an occasional wet mopping to stay clean and new looking. If necessary, a more thorough cleaning with a detergent or ceramic tile cleaner will remove grime. To remove a particularly heavy accumulation of film from glazed tile, you may need a stiff brush and mild scouring powder. To clean joint between tiles, use a fiber brush and a mild cleaner. A special sealer for grout will make it more stain resistant.

Doors (Interior & Exterior)

Exterior Doors, inspect door trim and thresholds for wood rot, weather-stripping or water damage. Replace any deteriorated exterior caulking with a good quality latex caulk compatible with door and wall materials. Hinges should be secure, and knobs and locks functioning properly. Properly installed weather-stripping at exterior doors helps lower your energy bills, so keep it snug and in good condition.

After time, uncontrollable atmospheric factors (ranging from high humidity, salt, and rain, to extreme levels of direct sunlight) can cause brass hardware to lose its brilliance. Any sharp object like a door key, clothes hanger, knife, etc. can scratch the protective coating. Moisture then collects on the scratched surface and corrosion begins. Wet latex paint will cause brass to tarnish. Always remove door hardware from doors before painting. Make certain the latex paint has dried before reinstalling the door hardware.

Interior doors should latch properly for privacy. Hinges should be secure and knobs and locks functioning properly. If doors are not functioning properly, minor adjustments to the door frames receiver (striker plate) can be made to help the door to latch properly.

Sliding glass doors let us view and access the outdoors but also bring their own set of problems. Worn rollers or a dirty track can make doors hard to operate. Most rollers can be adjusted, and replacement parts for many types of doors are available at home centers, glass shops and screen shops. Sliding door lock failure is a common problem; locks should be kept in good working order. Many types of supplementary locks are available for sliding doors and are a good investment in home security. Sliding door screens are often neglected. Keeping rollers working smoothly and replacing torn screens will pay dividends when you want to feel the breeze on a nice spring day.

Garage doors and the surrounding framing should be examined for evidence of wood rot and physical damage. Check doors for proper operation and balance. (Release the automatic operator if one is present with the door in the down position.) The door should easily open to its full height and close smoothly without crashing to the floor. A balanced door will stay in place when opened to a height of five or six feet. Rollers and hinges should not be loose and should operate smoothly. Regular servicing of rollers and tracks will help keep them working well. Since springs are under great tension and can cause serious injury or damage if mishandled, the adjustment of door springs is best left to a qualified contractor.

From time to time, some doors can develop minor problems.

Sticking – is the most common problem with doors. If the sticking is caused by swelling damp weather, hold sandpaper around a wooden block and sand the edge that binds. If the hinge screws are tight and the door is still out of alignment, sand or plane the edge that binds. Paint or varnish areas that have been sanded or planed.

Not Latching - From time to time, doors may not latch securely enough due to settling of your home. To remedy the situation, simply loosen the screws of the keeper on the doorjamb and adjust it until the door fits snugly to the jamb stop.

Warping – is the result of too much moisture. If a door warps, the best remedy is to dry it in the sun. If the door is still warped after being thoroughly dried, apply weight to the bulged side and leave it for 2 or 3 days.

Storm Doors – may reduce your heating costs. Storm doors are usually made of aluminum, wood, vinyl-clad wood or solid vinyl. Homes with insulated steel exterior doors don’t need separate storm doors.

Weather Stripping – to maintain your home’s energy efficiency, exterior doors come equipped with weather stripping made from a variety of materials, including metal, plastic and rubber. This weather stripping must remain properly in place to prevent the loss of expensively conditioned air or infiltration of outside air. Metal weather stripping may have to be renailed if it comes loose. For rubber or plastic weather stripping, regluing or renailling should be all that is necessary.

Painting – wood exterior doors should be varnished every year or painted when the house or trim is painted every 4 to 6 years.

Garage Doors – moving parts of garage doors should be oiled every 3 months. The screws that fasten the hardware should be tightened every 12 months because the wood shrinks a little as it ages. An overhead door may warp inward from being left up for long periods. Usually this can be corrected by adjusting the nuts on the metal rods or the straps across the top and bottom of the door.

Locks – Locks requiring a key on the inside are potentially dangerous in an emergency. When this type of lock is used, keep a spare key always handy to prevent anyone from being trapped inside the house.

Windows

Open and close all the windows in your house. Clean and lubricate any that stick, and straighten any bent tracks. Bedroom windows must open fully and allow for fire escape; any security bars must have safety release mechanisms that do not require a key and can be easily opened in an emergency. Whenever a window pane breaks or cracks, it should be replaced for both appearance and safety reasons. The Yellow Pages list many companies that can repair the window.

Lock replacement parts can be found in home centers and glass shops. Double pane windows fog when the sealed air space between the glass panes loses its seal, and moisture enters the cavity. Though these windows will still operate, they may become impossible to see through and should be replaced by a qualified glass company.

From the outside, inspect wood frames and sills for rot, and check the caulking around the frame. Any gaps or cracks should be sealed with a good quality exterior caulk.

The horizontal windows in your bedrooms, baths and kitchens come with “weep holes” for drainage. These small holes allow moisture or condensation to drain out. The window track should be kept clean to allow these holes to function properly.

Window treatments such as blinds or drapes not only add to the beauty and value of your home, they also aid in the proper function of your heating and cooling system. When your window treatment does an effective job of keeping heat out in the summer and cold out in winter, your air conditioning and heating systems operate more efficiently. We suggest, for best results from your system, that some type of window covering be installed as soon as possible after you move into your new home.

Window Screens

An annual inspection of your window screens should be made. You should repair or replace any missing or damaged window screening. Most of the repair supplies you would need can be found in your local home center. By keeping your window screens in good condition, this will help prevent insects and other unwanted pests from entering your home. Solar screens would be a good alternative to the standard bug screening.

Solar Screens will keep the unwanted pests from entering the home and help lower your utility cost. Solar Screens are exterior full-length screens that cover the entire glass of your windows and doors. Solar Screening is a woven vinyl-coated fiberglass screening manufactured for the primary use of reducing solar heat gain in the summer and reducing heat loss in the winter. It also performs as an insect screening. Solar Screening is virtually maintenance free. It is noncombustible and will not rust, corrode, shrink, scratch or stain.

Solar Screens work in three different ways:

1. **Shading Coefficiency** – the amount of shade created between the solar screen and exterior pane of glass.
2. **Reflectivity** – reflecting the direct sun’s rays of light off of the screen, not letting the heat touch the glass.
3. **Absorption** – the heat that is absorbed and held into the screen material itself and then dispersed back into the air away from the glass.

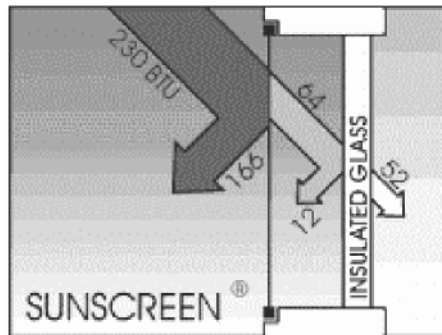

TOTAL 230 BTU	Blocked by SunScreen	Blocked by Insulated Glass	Allowed Inside	Percentage of Total Allowed Inside
U protected Insulated Glass	N/A	44	186	80.9%
with SunScreen	166	12	52	22.6%

Fireplace / Chimney

When the weather begins to cool and leaves start to fall, it’s time to check out the fireplace. Visually inspect the firebox, looking for loose or shifted bricks (if brick). If necessary, have a qualified chimney sweep replace them and repoint mortar cracks. Check the damper for proper operation and inspect the flue. Excessive soot or creosote buildup should be removed to prevent a chimney fire. Gas log lighter pipes should be free of excessive corrosion and should burn evenly along their entire length. Helpful hint: To help prevent ashes from clogging the gas holes in the lighter pipe, install the pipe with the holes pointed side-ways or down.

Whenever the fireplace is not in use, be sure to close the damper to prevent heat or cooling loss “unless you have gas logs installed in the firebox”. Always make sure the damper is open before you build a fire. Under current building standards, when artificial gas logs are installed in a firebox, with a damper, it should be permanently blocked open to prevent spillage of combustion product into the room.

If possible, turn off your heating when using the fireplace. If you choose not to turn off your heat, it may be necessary to open a window in your family room to provide maximum ventilation and draw for the fireplace.

Periodic maintenance should include touch-up caulking between the fireplace and wall.

Inspect the chimney crown for cracking (masonry) or rusting (metal). Cracking or rusting should be repaired to prevent water penetration and deterioration. The rain cover and spark arrestor screening should be in good condition. If none is present, after-market cap/screen units are available. After measuring the top flue tile for size, purchase and install one. If the chimney is wood, be sure that wood and trim and sound; if masonry, that bricks or stone are not loose or cracked, permitting water penetration.

Fireplace Safety

If constructed properly, fireplaces will perform safely and dependably. Fireplaces, just like anything else, wear over a period of years and need to be maintained to extend their life. Here is some information for safely maintaining and operating a fireplace.

Maintenance for Safety

- Keep the fireplace in good condition by repairing cracks in the flue lining, bricks and mortar.
- Keep the flue clear of soot, creosote and obstructions. Inspect the fireplace and chimney at least once a year to prevent creosote buildup.
- Install bird and animal guards on the chimney. Squirrel and bird nests can stop up chimneys.
- If you choose a natural gas "log," follow instructions for installation and use. Look for the American Gas Association label.

Safe Operation

Equip the house with fire-warning devices. Install a type ABC fire extinguisher near the fireplace. Install a screen that completely covers the fireplace opening to keep sparks from flying out. Keep combustible materials such as carpets, furniture, paper, logs and kindling at least 3 feet away from the fireplace. Arrange andirons so logs can't roll out.

Use only enough fuel to keep the fire at the desired temperature. Avoid "roaring" fires. They can start chimney fires from soot and creosote deposits in the flue.

Do not use gasoline or other flammable liquids to kindle or rekindle a fire because the flammable vapors can explode. Never use fuels near a fire; explosive vapors can travel the length of a room.

Keep the damper open while the fuel is burning to provide for efficient burning and to prevent accumulation of poisonous or explosive gases.

Never burn Christmas tree greens. They cause many sparks when burning and can cause a chimney fire. Remove colored comic sections before rolling newspapers into logs. The colored inks contain lead and can produce toxic gases.

Do not use coal, charcoal or polystyrene packaging in a fireplace unless the fireplace is designed to handle the excess heat and smoke which occurs when burning these materials.

Do not treat artificial logs (made from sawdust and wax) the same way you treat real wood logs. Use only one at a time. If you use more, they can produce too much heat for some fireplaces to withstand.

Keep children away from the fire because their clothing can easily ignite. Warn the entire family about this hazard.

Be sure that all ashes have thoroughly cooled before you dispose of them. Put ashes in a lidded metal container to prevent a possible fire and provide a sturdy place to store them. Ashes make good fertilizer in gardens, flowerbeds, etc. Be sure the fire is out completely before retiring for the evening.

Safe Supply of Air

A fireplace fire requires about 5 times as much air as most houses need for liberal ventilation. With today's tightly-constructed houses incorporating weather-stripped doors, caulked windows and self-closing exhaust vents, a fireplace can set up reverse draft and suck poisonous carbon monoxide fumes from combustion-type (natural gas, etc.) water heaters or furnaces and discharge them into the living area.

In tight homes, the fireplace may also consume enough oxygen from the air in the house to cause problems to occupants. To be safe, a positive source of outside air should be supplied to all fireplaces and wood-or-coal burning stoves to bring in enough fresh air for efficient burning. This can be provided by installing an outside air vent or opening a window when the fireplace or stove is being used. To keep smoke from entering the room, turn off kitchen and bathroom exhaust fans and close the registers of forced air heating systems which are near the fireplace.

Porches, Decks & Carports

Inspect deck and balcony steps and surfaces for loose fasteners, “nail pops” (nails backing out), rotted wood and proper operation of gates and latches. Replace rotted boards and framing members. Loose fasteners should be removed and replaced with ring shank nails or decking screws for better holding power. Aluminum or stainless steel fasteners cost more but will not rust. Rebuild any loose, missing or rotted railings, benches or steps. Current safety standards require decks or balconies with a height of thirty inches (30”) or greater off the ground adjacent to the deck or balconies to have railings and the balusters spacing to be four inches or less to prevent the passage of small children.

Dirt, mold and mildew can be removed from deck surfaces by power washing. Power washing equipment can be found at most rental centers. After the surface is clean, finish with a deck sealant or wood stain for a longer lasting, better looking deck.

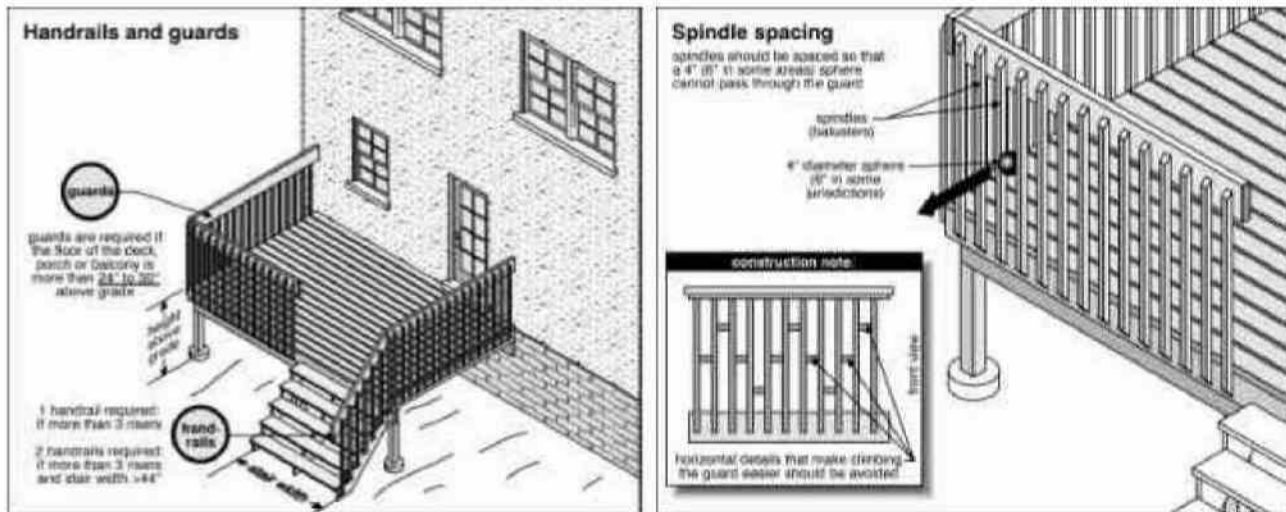

ELECTRICAL SYSTEMS

Service Entrance & Panels

Your home's electrical system is probably the lowest maintenance system in the house, if installed properly. Proper installation must also be accompanied by proper use. All systems have limitations that once exceeded can lead to damage and loss of property and personal injury or death. Original electrical systems often times become dangerous as they are expanded without increasing the size of the main power feed to the house. The expanded uses cause the original feed (known as the Service Entrance Cable) to draw more current than it is rated to carry, resulting in overheating and possible fires. Since the home inspection is not technically exhaustive and since any device or system can subsequently fail, we suggest that you keep the following basic rules / practices in mind.

- Never use exterior or interior extension cords for permanent wiring. Do not use interior extension cords in traffic areas where they can be damaged.
- Do not use light bulbs that are too strong for the stamped rating of the light fixture.
- Do not use light bulbs over twenty-five watts in a small closet.
- Do not crowd light or fan fixtures in the attic with any combustible material.
- Replace small appliance flex cords that get excessively hot from moderate use, such as clothes iron after operated for 15 minutes.
- NEVER WORK ON THE ELECTRICAL SYSTEM WITHOUT CLEAR UNDERSTANDING OF ELECTRICITY AND WITHOUT FIRST TURNING OFF THE POWER.

Exterior Electrical Connections

Electricity is supplied to houses through overhead power lines or underground cables. Visually inspect overhead lines for contact with trees or shrubs, and call your electric utility company to inform them of any such contact. Advise them also of the following: a power line less than 10 ft. above a yard or 12 ft. above a driveway; improper connection or anchoring at the service mast or building (check for signs that wires, cables and anchor bolts have pulled loose); and frayed or damaged wiring cables. For underground service, check for loose connections and damage to electrical conduit at the meter and main service panel. Remember that you cannot disconnect the power on the supplier side of the meter (from your meter to the pole), so all these conditions present a hazard and should be professionally repaired right away.

Service Panel Box (Breaker Box)

Inspect the main service panels to be sure that the inside cover is properly secured in place and there are no broken breaker handles, open breaker slots or missing knockouts in the inside cover or panel box. Blanks are available to fill open breaker slots to keep out nesting wasps and lizards, and to protect seven-year-old electricians with screwdrivers. Breakers that repeatedly trip indicate a serious problem and must be investigated by a qualified electrician. For your safety, do not remove the inside panel cover. Leave the inspection of panel interiors to professionals.

Be careful not to overload any one circuit with too many appliances. The electrical system in your home is equipped with an electrical breaker box. Each breaker should be labeled as to which circuit it controls. You can stop the flow of electricity to a given circuit simply by flipping the breaker to an off position. Should you find that an electrical device in your home is not working, check your breaker box to make sure that the device is getting electrical power.

The breaker box should be readably accessible and the cover plate (dead front) should be easily removable at all times. You should never place items in front of the breaker box. The breaker box cover plate (dead front) should not be painted or paneled over and any time.

Aluminum Wiring

The U.S. Product Consumer Safety Commission issued a booklet on the hazards of aluminum wire installations made in the early 1960's to mid 1970's. Please obtain this information if aluminum wiring is noted in your property inspection report.

You can contact the CPSC by writing them at US Consumer Product Safety Commission 4330 East-West Highway Bethesda, Maryland 208 14-4408 (1-800-638-2772) or via the Internet at www.cpsc.gov.

Branch Circuits

Check interior and exterior receptacles and switches for broken or missing wall covers, broken parts, and for those not working or hot to the touch. Replace broken or damaged receptacles and missing or broken covers (for weather protection).

Dimmer switches or switches controlling multiple lighting fixtures may need lower wattage bulbs to prevent overheating. Carefully read and follow instructions when installing dimmer switches or rheostats on lights or ceiling fans. Before attempting any electrical repairs, be sure the power has been shut off at the appropriate breaker and that you are properly observing safety precautions. *If you have any doubts or are not completely comfortable working with electrical wires or appliances, **don't do it!!** Call a qualified electrician.*

Also, the light fixtures in your home are designed for 60-watt bulbs. Continuous use of higher wattage bulbs may eventually burn up the light fixtures. Also, the use of a high-watt bulb in wallpapered vanity areas may cause wallpaper to peel from the walls.

DON'T BE SHOCKED

Ground Fault Protection (GFCI's)

(Refer to Illustrations on page 20)

Electric outlets called Ground Fault Circuit Interrupter (GFCI) receptacles save lives by cutting power to appliances that may short out and shock you. Current safety standards require ground fault protection at all receptacles serving kitchen countertops, in all bathrooms, within six feet of bars or laundry sinks, all of the garage receptacles (if undedicated), and all outdoor receptacles. Many older homes lack this protection. GFCI receptacles should be installed by a qualified electrician at all required locations.

Periodically test GFCI receptacles by pressing the “test” button to interrupt power and the “reset” button to restore it. A lamp or other small device plugged into the receptacle should turn off and on accordingly. Inexpensive circuit testers with GFCI testing capability are available at most home centers and hardware stores. Defective GFCI receptacles should be replaced by a qualified electrician.

We recommended that you do not connect large appliances (such as freezers) to a receptacle on a GFCI circuit.

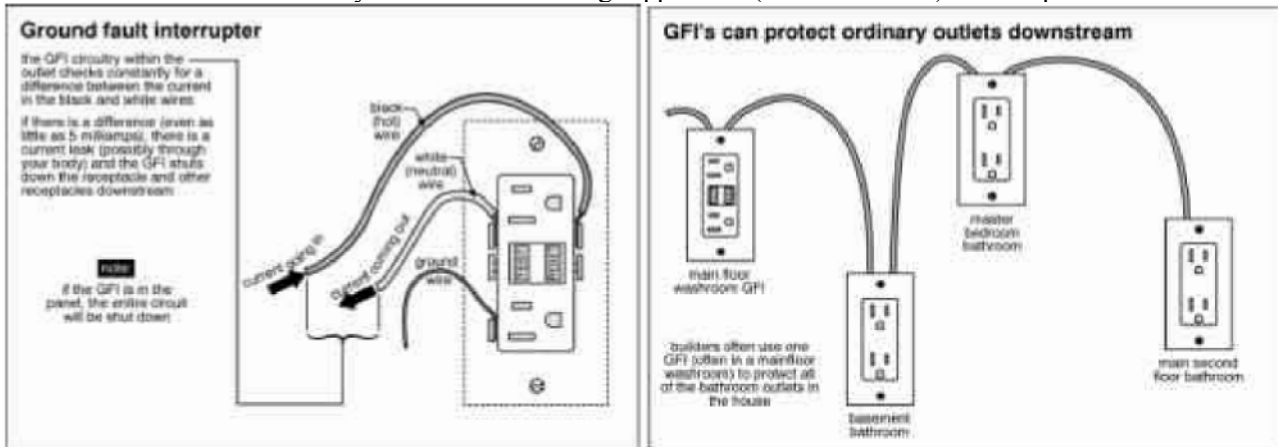

Ceiling Fan

Ceiling fans can fall. Any fan weighing more than 35 lbs. needs special support equipment like braces, steel outlet boxes that grip the ceiling joist in the saddle fashion. Most of our problems with ceiling fans pertain to pre-1980 models and the use of antique, heavy Casablanca units without ceiling bracing. Other than the above listed items, your ceiling fan is nearly maintenance free. Most fans have sealed bearing and do not require oiling. To keep your fan free from dust and dirt build-up, periodically vacuum the blades with a soft brush attachment or gently wipe clean with a damp cloth.

Smoke Detectors

Each month press the test button on your detectors to be sure they work, and at least once a year (the start of daylight savings time is a good reminder) change all batteries. To check a detector that does not have a test button, simply blow smoke into the detector to trigger the alarm. Recycle the alarm batteries in entertainment remotes or kids' toys, where their possible failure isn't a life-or-death matter. If you don't have smoke detectors, install one in each bedroom and in bedroom halls.

Smoke detector units should be vacuumed cleaned every 30 days to prevent dust build-up, which could activate the alarm.

Carbon Monoxide Detectors

If you have gas appliances, consider installing carbon monoxide detectors near furnaces and water heaters. All of these alarms are a very minor expense weighed against their usefulness in an emergency.

Fire Extinguishers

You do have one, don't you? Be sure the fire extinguisher is suitable for all types of fires (it should be marked "A, B, and C" to indicate this) and is conveniently located. Make sure all family members know the location of the extinguisher, and how to operate it. Each month check that the fire extinguisher is fully charged and has not passed its expiration date.

HEATING, VENTILATION AND AIR CONDITIONING SYSTEMS

Heating Equipment

Note: A semi-annual service contract with a qualified HVAC (heating, ventilation and air conditioning) contractor to inspect and service your heating and air conditioning equipment will keep your system operating efficiently and extend its life.

KEEPING COMFORTABLE

Due to changes and variances in temperature and humidity, your heating and air conditioning system is one of the more important features your home has to offer.

Inspect the combustion chamber in gas-fired furnaces to be sure a bright blue flame is visible along the entire length of burner pipes. A yellow flame or excessive scaling, rust or soot indicates improper combustion and/or a possible leak in the heat exchanger that could allow combustion gases and carbon monoxide to enter your living area. This potentially dangerous situation requires professional inspection and repair.

Electric heat requires little homeowner maintenance. Simply be observant, and if the unit does not seem to be heating adequately, or has to run all of the time, call your HVAC contractor to evaluate it.

If the system is installed in midsummer, it cannot be checked for operation of the heater. At the first sign of cool weather, you should turn on the heater to check it. Even if heat is not yet needed! The first time you turn on the heat, the unit may blow smoke for a minute or two because of the oil used on the furnace to prevent rusting during shipment. (This could cause your smoke detector to sound its alarm.)

Your heating and air conditioning system not only controls temperature but also controls the humidity in your home. Don't leave windows or doors open while your system is in operation. If they are left open, condensation will form on the air conditioning vents and on the inside of the windows. Often, this moisture will stain the sheetrock or woodwork and may cause the unit to freeze up, possibly causing permanent damage.

IMPORTANT: MOST WARRANTIES DO NOT INCLUDE:

Cleaning or changing filters, adjusting thermostats, cleaning condenser coils, problems caused by insects or debris in the equipment, or tripped breakers.

Before calling for service:

1. Check filters to ensure they are clean
2. Check breaker or fuses; confirm they are in the "on" position
3. Check switches; confirm they are in the "on" position
4. Check thermostat; to see that it is set properly.

Please call your heating and air conditioning supplier/contractor if you need service.

Thermostats and Controls

Visually inspect the wall thermostat for any damage or missing parts, and repair as needed. Programmable thermostats have a battery that must be changed if the LCD readout indicates the battery is weak. There is also a "fan limit switch" that ensures greater energy efficiency. If the blower either runs continuously after turning off the heat or shuts off immediately, the fan limit switch may not be functioning properly; a qualified HVAC contractor should service the unit.

Your air conditioning may include a "set-up, set-back" thermostat to keep a comfortable temperature during those hours you're at home; and to run on more efficient temperatures when you're away or asleep.

Cooling Equipment

Maintaining your cooling equipment is largely a matter of keeping the inside and outside units clean. This means a regular filter replacement or cleaning program, an occasional duct cleaning (every five years) and keeping the outside unit clear of weeds, dirt, debris, coil pings, and dents from lawnmowers, baseballs, etc. Inspect coil fins for damage and make repairs if needed. HVAC contractors have special tools for straightening bent coil fins. Manufacturers

recommend at least two feet clearance around and five feet above the unit. Remember that dirt and dust are insulators and they, therefore, make it more difficult to transfer heat from the inside air to the transport medium (refrigerant) and ultimately from the outside coils (Condenser) to the outside air. Listen for unusual fan or motor noise that might signal impending failure. Watch for fire ants that may invade the unit and cause serious problems. Use of an insecticide around the condensing unit to control fire ants is a wise preventive measure.

Electric Compressors and Heat Pumps are now rated (for cooling purposes) by their “Seasonal Energy Efficiency Ratio” or “SEER”. The SEER is the ratio between the total cooling output during the normal season divided by the total electric power input for the season. For example, a 10 SEER means that the BTU/h is ten times the input. The higher the SEER, the lower the operating cost and the higher the efficiency. However, past a certain SEER level more is not necessarily better because the system can cool the house off too fast to remove significant humidity from the air. A properly cooling system should drop the temperature 15 – 23 degrees across the inside coils (evaporative coils). Remember, however, that on an extremely hot day you may not get the same performance. Air Conditioning, by definition, is the equipment’s ability to drop the inside temperature 15 degrees below outside temperatures. Therefore, if the outside temperature is 95-105 degrees, and the inside temperature is 80 degrees, then we have properly operating air conditioning. Try to keep your thermostat set at 80 degrees if you are relaxing and 75 degrees if active.

Most air conditioning systems feature a double drainage system. The primary drain is connected into your main plumbing system. An auxiliary or back-up drain from your air conditioner is tied into a pipe leading outside your home. While this drain acts as a back-up system, it also can be considered a “red flag” warning that your primary drain is not functioning properly. If you notice water coming from the auxiliary drain, you should inspect the primary drainage system for an obstruction or blockage in the pipes. To kill fungus and keep your air conditioner running smoothly, pour one cup of a 50/50 solution of chlorine bleach and water into the opening at the condensate drain line where it exits the evaporator coil. Doing this in Spring and Fall will also prevent condensate from backing up into house and flooding the area. Check the flow of water through the condensate drain by observing flow at its termination or the flow of water in the pipe. If the drain does not flow freely, simply blowing it out may solve the problem. This drain line should terminate at least five feet from your home’s foundation to prevent a wet area at the foundation edge.

If the system is installed in midwinter, it cannot be checked for operation of the cooling. At the first sign of warmer weather, temperatures averaging above 60 degrees Fahrenheit, you should turn on the air conditioning system to check it... even if cooling is not yet needed

By following the above procedures and properly maintaining the heating and air conditioning system in your home, you and your family should be quite comfortable for many years.

Ducts & Vents

Return Air Filters

The single most important thing a homeowner can do to keep the HVAC (heating, ventilation and air conditioning) system operating at peak efficiency is to keep the return air filters clean and properly secured in place. The filters should fit snugly. If they lift when the blower comes on, unfiltered air is bypassing the filter. The heating and air conditioning filter should be changed on a regular basis. For best results, we suggest installing a new filter every 30 days. A good overall filter is a pleated polyester type. If you have allergies try an electrostatic filter. These require no external power source and can be purchased in various sizes. **Caution** if you are not good at doing household chores- the electrostatic filter must be cleaned monthly or it can ruin your heating and cooling system. Also, be careful not to block the return air grill with furniture or other obstructions.

HVAC Ductwork

Significant amounts of conditioned air can be lost to the attic through leaky ducts. Inspect ductwork for leaks at connections and joints, proper support, tight bends and general condition. During the 1 980s a flexible duct with a gray plastic covering was used extensively. This gray plastic covering deteriorates in attics. Damaged ductwork should be replaced as necessary.

If there are rooms in your home that are not being used, we suggest that you shut down the airflow to those rooms, this can be done by closing the register or vent located in the ceiling, floor or wall of each room. This serves two functions: heating or cooling is not wasted in an unoccupied room, and you increase the airflow to the rest of your home.

PLUMBING SYSTEM

Water Supply System Fixtures

Water Meter

Locate your homeowner's main water shut-off valve. The water meter is usually located on the left or right property line, approximately two feet from the curb. Be sure it is not leaking and is easily accessible and operating in case of an emergency. Fire ants are a common problem. Keep the cover in place and the enclosure cleaned out.

If a water leak occurs at the meter, it should be determined which side of the meter is leaking. To do this, you should cut off the main valve to your home. If the indicator on the meter continues to turn, the leak is on the house side of the meter. If this is the case, notify your Plumbing Contractor immediately.

If, after you cut off the main valve to your home, the indicator on the meter stops turning, the leak is on the city side of the meter. If this is the case, contact the water company's emergency repair department immediately.

Close and open the main water supply shutoff valve (periodically) to ensure that it has not stuck in the open position. Check fixture shutoff valves periodically as well. Both the main valve and fixture valves must be operable so water can be turned off in an emergency or when plumbing repairs are necessary.

Exterior Plumbing

Inspect all exterior faucets for leaks. There are typically two outside hose bibs, usually located on opposite sides of your home. *Care should be taken when pulling a garden hose, so not to apply too much pressure on the hose bib itself.*

A single dripping faucet can waste hundreds of gallons of water a year. Also inspect for broken handles and the presence of backflow (anti-siphon) protection on each faucet. Backflow protection devices for exterior faucets are readily available and are intended to prevent contamination of drinking water caused by back siphoning. Before cold weather comes, unscrew, drain and store garden hoses inside for the winter. Install insulated covers on outside faucets to protect them from freezing weather.

Crawl Space Plumbing (Pier & Beam Homes)

Again: an annual inspection of the crawl space is best left to a qualified inspector. If you must do it yourself, follow these safety tips. Always let someone know where you will be, wear sturdy coveralls and a dust mask, carry a bright light and avoid contact with any electrical wiring. The crawl space should be clean and dry. Nothing should ever be stored in the crawl space. Before entering the crawl space, turn the interior water fixtures on at the sink/lavatories, tubs, and showers and flush each commode/toilet at least twice. (**CAUTION: NEVER ENTER A CRAWL SPACE WITH STANDING WATER.**)

While under the house, look for evidence of animal and insect infestation, leaking plumbing and anything else unusual like damp or rotted wood in bath and kitchen areas.

Inspect distribution and drainage pipes for leakage or signs of weakness (annually). Giving extra attention to the drain lines at the commodes, bathtubs and shower enclosure areas. Look for rust, corrosion, greenish deposits, and mineral deposits around fittings, valves and along the length of the pipe. (**Note:** Water from small holes can evaporate before a drip forms, leaving only a telltale whitish or colored deposit.)

Check the insulation on all of the water distribution lines. Replace any damaged or missing insulation. This will prevent water lines from freezing in the winter time and help the hot water lines hold their heat longer. After completing your inspection, be sure that the access hatch cover is in good repair, fits the opening properly and is securely closed.

Interior Plumbing

Sinks & Tub Faucets - Daily use of water faucets in the house should make it obvious when they are hard to turn off, start to drip or splatter water on countertops. Dripping faucets are usually caused by worn or damaged washers. *To prolong the life of the washers, turn the faucet only hard enough to stop the flow of water.* Replacing faucet washers can usually repair dripping faucets.

If washer type, replace faucet washer and check washer seat for roughening; smooth if needed. If washerless, consult an installation manual or the personnel in a plumbing or hardware store for replacement procedures. Washers come in various sizes and may be bought at any hardware store for a nominal price. Washers are easily replaced with a Phillips screwdriver and a crescent wrench. Before replacing washers, be sure to turn the water off at the main cut-off valve. To replace a washer, remove the Phillips screw holding the handle onto the faucet itself. After this is done, use the crescent wrench to unscrew the brass connector which holds the stem and connected washer in place. Merely unscrew the

brass connector, and the stem and washer will back out into your hand. At this time, you can see and replace the worn-out washer by removing the Phillips screw that holds the washer in place. The faucet is then reassembled in the same fashion. Initially, some faucets will drip until the washers seat themselves.

Sediment in many water systems can build up in faucet aerators, restricting water flow and spattering water. To solve this problem, clean aerators on faucets (every three or four months, depending upon water hardness). Unscrew the aerator from the faucet spout, disassemble it (keeping parts in proper order), rinse away sediment, reassemble and screw the aerator back on. Occasionally it may be necessary to replace the aerator to achieve proper performance.

Periodically inspect supply shut-off valves under sinks for proper operation, corrosion and leaks. A leaking or inoperable valve can create a lagoon of trouble if not caught and corrected early.

Occasionally fill sinks with water and watch them drain while the water continues to run. A properly draining sink will empty faster than it fills. At the same time, look under the sink (a good flashlight helps) for leaks in the drain pipes. Bathtubs should also drain faster than the water runs, so you're not standing in a lake while showering. Repairing these simple plumbing problems early can help avoid bigger problems later.

Toilets/Commodes - Another big water waster is a running toilet. Here's an easy test to see if you have a problem. Put a few drops of food coloring in your toilet tank-don't flush yet. If any color appears in the toilet bowl, you have a leak. Replacing the rubber flapper in your tank will cost only a few dollars and save hundreds of gallons of water a month. While the lid is off your toilet tank, check flush mechanisms, handles, chain flappers and ballcock valves. A poorly adjusted or worn ballcock valve (also called a fill valve) can also cause a toilet to run. Running toilets are usually caused by a worn or sticking ballcock shutoff valve or a float that is too high.

After the toilet is several years old, a worn ballcock shutoff valve is normally at fault and requires replacement. Ballcock valves are easily replaced and are available at any hardware store. Make sure your replacement ballcock valve is an anti-siphon type, where the valve assembly is above the overflow tube in the toilet tank to avoid back siphoning and contamination.

If the running is caused by a float that is too high, the level can easily be adjusted downward. Merely unscrew the float itself, causing it to move further out on the arm of the float. For the best operation, the water level in the tank, when full, should rest at the waterline stamped inside the tank. Since usage will affect adjustment, the water line should be checked whenever your toilet begins to flush abnormally. Also make sure the toilet is anchored securely to the floor, with no leaks between bowl and tank or at the water supply valve on the wall.

Bathtubs>Showers - Some bathtub recesses and shower enclosure walls are covered with ceramic tile. Through normal house settling and usage, some separation at the grout (mortar) and/or caulk lines may occur. Other areas to be watched include the base of the tub and/or shower and the joint between the tile and tub/showers. These cracks should be filled with a compound such as tile putty, grout, or tub/shower caulking, available at all hardware stores. These cracks should be corrected promptly, as they allow water to get behind the gypsum board or vinyl floor covering causing further damage.

Marble Tubs - If yours is a marble tub, use liquid detergent (without abrasives) to remove residue. Never use wire brushes or metal tools on any part of the tub. Liquid cleaning compound (such as is used for cars) with a light application of liquid wax or paste will restore dull surfaces. Clean plated surfaces with water only. Do not use any ammonia based or abrasive cleaners as this will harm the plating on knobs, jets, etc., and void the warranty on plated finishes.

Laundry Connections - Check laundry faucets and washer connections for leaks and corrosion. Corrosion at faucets indicates small leaks that can turn into big leaks. In hard water areas, periodically clean the screens in the hose at the washer connections. Consider replacing old worn hoses to prevent bursting and flooding. If a floor drain is present, pour a cup of water in it and check the exterior termination to be sure it is not clogged.

Clogged Drainage Lines

When waste water gurgles and seeps slowly away from sink, lavatory, bathtub, shower or toilet bowl, there is probably foreign material in the waste line slowing the flow of water. Most of the time, clogged lines may be opened by using a "plumber's friend," or water plunger.

Sink & Tub Drains - Usually the problem is hair and soap curds caught in the stopper. Check first to be sure all of the other drains in the house are working. If a regular rubber stopper is used, the hair is properly hanging on the screen in the drain pipe just below the stopper. Take the screen out and clean it. Next use a plunger which applies first pressure and then suction to the plugged drain. To provide suction and pressure, smear a good layer of petroleum jelly on the edge of the rubber plunger. Then plug the overflow with a wet rag so air will not short circuit through the overflow pipe. Pump the plunger to loosen the stoppage. If this loosens the plug, rinse the drain with hot soapy water.

If the screen can't be removed and the plunger does not seem to help, try removing the hair and trash. Take a piece of wire (a regular hair pin, or thin coat hanger), put a very short bend on one end maybe 1/4" or less. If the piece of

wire is very short, bend the other end so you can hold onto the wire and turn it without dropping it. Work the hair back out of the drain. This may take practice until it is all out. After all of the hair has been removed, flush several cups of hot water down the drain. This should allow the bowl to empty.

Ordinary detergent added to a drain on a regular basis will help to keep it clear of the grease from soap and cooking utensils. Run hot water through the drain, turn off the water, add 3 tablespoons of detergent and follow it with enough hot water to wash it down the drain opening. Let it stand 15 minutes and run more hot water. To avoid clogging drains or toilets never pour grease into them.

Toilets/Commodos - To ensure that toilets or waste lines do not become clogged, never dispose of hair, grease, fish scales, lint, diapers, sanitary napkins, rubbish or any solid matter in your plumbing system. Back-ups in toilets can sometimes be alleviated by removing the sewer clean-out cap from the sewer clean-out located outside. This will allow the overflow to back up outside, rather than in the house. (Of course, the source of the backup must be discovered and the problem corrected.)

First try a "plumbers friend" or plunger. A plunger for the toilet is different than one for a lavatory, although there is a type which can be used for both. If this does not clear the stoppage use a plumber's snake made for a toilet. This differs from a lavatory snake because it has a section of tubing which can be pushed into the liquid in the toilet

Should you have a stoppage that needs the assistance of a "Roto -Rooter" type service, beware that the device can cut its way through and damage the PVC drain pipe under your property. If the plunger or the snake does not remove the stoppage or if you are unsure on how to operate this equipment **"Stop"!!** Call a professional plumber and let them handle it for you.

Plumbing Fixture Care

Don't:

- Let food waste stand in the sink. If you have a garbage disposal, dispose of food waste as it accumulates. If you don't have a disposal, put the waste in an appropriate container.
- Step in a tub with shoes on. Soles carry gritty particles that will scratch the tub's surface.
- Use bathtubs or sinks as receptacles for photographic or developing solutions. These stains are extremely difficult, sometimes impossible, to remove.
- Leave wet metal utensils on the surface of the sink, as this will cause rust stains. Steel-wool soap pads will rust and stain when wet, and should be kept in an appropriate container. To remove rust stains use a commercial powered rust-remover and follow the manufacturer's directions carefully.
- Pour grease down kitchen drains; pour liquid grease from cooking into empty tin cans and set in refrigerator until solidified; put can into tightly closed plastic bag, wrap in newspapers, and put into trash bag.

Do:

- Eliminate food stains on white sinks by using a mild solution of chlorine bleach and rinse well. For stubborn stains wait 5 minutes before rinsing.
- Remove scum of grease and soap made insoluble by hard water minerals, by cleaning the fixture with a solution of 1 tablespoon Calgon in 1 gallon of warm water. A solution of vinegar and water is milder, and is also effective if the buildup is not too great. These solutions also work well on shower doors and shower door tracks.
- Clean porcelain fixtures and marbled vanity tops with non-abrasive cleaners.
- Clean glass shower stalls with ordinary dishwashing detergent unless hard water minerals have built up. For these use a commercial glass cleaner.
- Remove the old caulking around your bathtub or sink if it should dry out or crack and replace it. If you don't have a caulking gun, caulking material can be bought in applicator tubes or in disposable guns.
- Flush kitchen sink drains daily with scalding water. For grease buildup, dissolve 1 pound washing soda in 3 gallons of boiling water and pour down the drain. To avoid burns from boiling water, hold water container close to drain and pour slowly and directly into drain. For heavy grease buildup, use a commercial drain opener.
- Periodic use of a drain cleaner will prevent accumulations in the pipe. Be sure to read and follow directions on the container. Do not have your head over the drain when you pour the cleaner into the drain. The violent reaction of the cleaner in water can blow up in your face.
- In sinks or tubs where hair is washed, use a plastic or metal "hair catcher" or screen to catch hair before it gets into the drain.

IMPORTANT NOTICE FOR COLD WEATHER!

How to protect your home against freeze

During periods of extreme cold weather, your home is subject to freeze damage. In some areas, temperatures can drop dramatically as cold fronts come through, and in others, freezing temperatures may be a daily occurrence during the winter season. In all cases, freezing temperatures may cause damage to your home, and there are a number of preventative measures recommended for protecting your investment. It is important that you watch for forecasts of extreme cold weather, and take appropriate measures to protect your home. For your convenience, we have outlined several recommendations below:

Disconnect all exterior hoses from plumbing fixtures, and wrap all exterior faucets with insulating material. Most hardware stores carry such material, and you will also find faucet covers designed just for this purpose.

If you have a sprinkler system, you may need to turn it off and drain it during times of freezing temperatures.

Open the doors of any cabinets that are positioned on outside walls to allow warmer insider air to circulate within the cabinets.

These are just a few of the steps you may need to take in extreme weather conditions. Tune in to your local weather station to stay abreast of the temperatures and forecasts, and to benefit from any protection tips that experts may have. Your local water company is another source of prevention information.

Water Heating Equipment

Your home should be equipped with an electric or gas water heater to provide hot water to your family as needed. A thermostat controls the temperature in your water heater and the thermostat temperature setting should be checked. Many plumbers recommend 120 degrees F as a maximum setting. This will help conserve energy and provide you with a comfortable water temperature.

Water heaters should be visually inspected for leaks or corrosion at supply pipe fittings at the top of the tank, and for rust or corrosion on the tank or at the drain valve located near the bottom of the tank.

Check the temperature and pressure relief valve at the top or the top 6" of the side of the hot water heater (annually) to be sure the lever is functioning. Consult the operating manual or ask a qualified plumber to show you the procedure. Before testing, check for proper connection of the drainpipe to the T&P valve and the proper termination of the drain line. (According to the building standards for this region, the temperature/pressure (T&P) relief valve drain line should run gravitationally downwards, at all points, to the exterior of the

structure, turn downward and terminate within 6" of the ground or finished grade.) . If the valve does not work, have it replaced.

Most manufacturers recommend periodic flushing of both electric and gas water heaters. Open the drain valve located at the bottom of the water heater tank and drain 2 or 3 gallons of water from the heater to remove any sediment that may have accumulated in the tank bottom (semiannually; if drain water contains a high degree of sediment, drain more often). (**Note:** If this procedure is not done regularly, residual sediment particles may prevent the faucet valve from reseating properly upon closing and the valve washer may have to be replaced.)

If insulation has been mounted on the exterior of the water heater tank, inspect it to ensure that the insulation remains in the proper position, noting particularly that it is not blocking the combustion air inlet or the exhaust vent of gas units (quarterly).

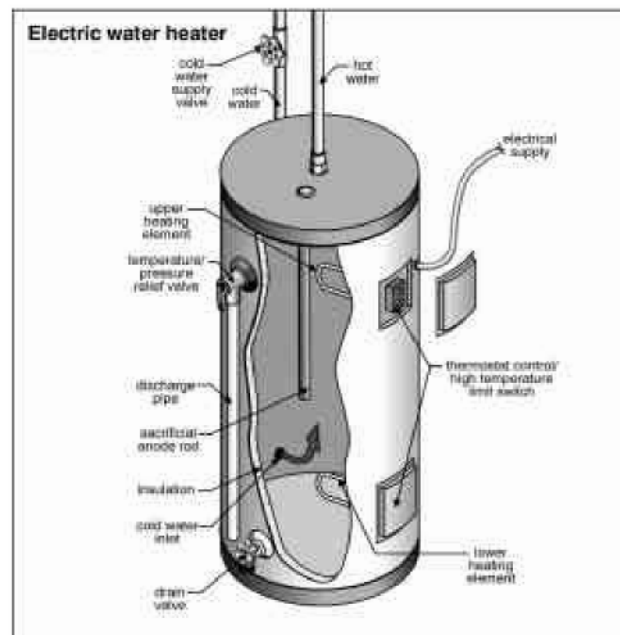

Water Heaters located in the garage or compartments opening into the garage should be mounted at least 18" above the garage floors lowest elevation. This helps protect the water heater from physical damage and help prevent to possibility of causing fires by igniting hazardous paint, gasoline or other flammable vapors.

Warning: Water heater closets or compartments should not be used for storage of any type. Special caution should be used to keep flammable products (i.e. gasoline, paint products, solvents, adhesives) in tightly sealed approved containers far way from any water heater, boiler or furnace and out of reach of children. Vapors from flammable products can catch fire causing damage, death or severe injury.

Gas Water Heater

Gas water heaters require slightly different maintenance procedures. At least every three months, a visual check should be made of your water heating venting system to check for obstructions, damage, or deterioration, which could cause leakage. At this time, also make a visual inspection of the main burner and pilot burner of your water heater. An odorant is added to the gas used by your gas water heater. If you smell gas, open windows, don't touch electrical switches extinguish any open flames, and immediately call the gas supplier. Also, for your safety, do not store or use gasoline or other flammable vapors and liquids near your gas water heater or any other appliance.

Gas-fired water heaters should be checked for excessive rust and scale on the burner compartment and for a bright blue flame. If rust and scaling exists in the burner area, it can be removed with a standard shop-vac, using the right precautions.

Inspect the exhaust stack on gas fired water heaters to ensure that all pipe connections are secure and free of rust, corrosion, and obstructions (annually). (**Note:** It is essential that fuel fired water heaters vent their gasses to the outside; escape of gasses inside the home could be lethal and pose a fire hazard.)

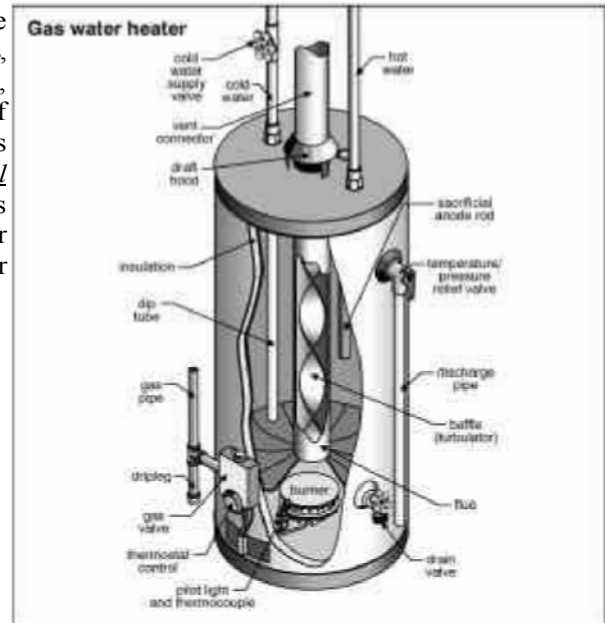

Water Interruption

To avoid having the heating elements burn up in your electric water heater, you should follow these suggestions.

Whenever water service is interrupted, the 220-volt breaker marked "Water Heater" should be flipped off or gas turned off immediately. To ensure that the heating elements do not become dry, causing them to burn up, there are three simple steps that should be followed before turning the electricity/gas back on to the water heater.

Step One Allow water to run at least five minutes after turning water back on.

Step Two Bleed pop-off valve (located on top of water heater) at least two or three times to ensure that no air is trapped inside the heater.

Step Three Allow hot water faucet inside home to run until all air has escaped from lines.

After these steps, you may turn the electricity/gas back on to the water heater. If gas service is interrupted, the pilot burner will have to be re-lit.

Hydro-Therapy Equipment

If a whirlpool tub is in one of the bathrooms, it will be a source of comfort and pleasure for years, provided it's properly cared for.

The following suggestions will enable you to enjoy and maintain your whirlpool:

- Check to make sure the water jets are not pointed upward.
- Do not turn on the system until the tub is completely filled. To properly fill the tub for use, fill the tub (1" above the highest jet) with warm to hot water.

- Use the pneumatic (timer) switch on the tub to turn the system off at a pre-set time.
- Do not allow any small objects such as toys or marbles to enter the jets or suction. Children should not be allowed to operate the whirlpool without supervision.

To prevent build-up of mineral deposits and soap scum, it's important to clean your whirlpool regularly. For normal cleaning of the tub surfaces, **DO NOT** use abrasives, steel wool, scouring pads, scrapers or sand paper on any part of the tub. (See section on marble tubs for cleaning suggestions). Non-abrasive commercial cleaners are effective for normal cleaning of the tub surfaces.

Regular use of the whirlpool should help reduce build-up within the jet system. Cleaning after prolonged inactivity can be accomplished by a few drops of a cleaner such as "Pinesol" in a full tub of water. Follow this cleaning by a thorough flushing of the system.

Ground Fault Circuit Interrupter (GFCI) Protection

Under today's building standards, all hydro-therapy equipment should be protected with a Ground Fault Interrupter device. This protection device can be located in the service panel box or in the same bathroom as the hydro-therapy equipment. If your hydro-therapy equipment is not protected by a GFCI circuit, than have one installed for your own safety.

Inspection Plates

Inspection Plates are used to cover the access holes to the main water cutoff and tub drains. The plates are secured by four screws which may be removed and replaced as often as necessary. The location of these plates is usually determined by the design of your home and/or city building codes.

APPLIANCES

Dishwasher

Check the dishwasher for freely spinning washer arms, proper door spring operation and attachment to the counter. Close the soap dish door and operate the unit in the normal cycle. During the rinse cycle, open the door (washing should stop) to see if the washer arms are turning and the soap dish door has opened. When using the dishwasher, make sure no loose objects fall to the bottom to interfere with the rotating spray arm.

Remove the kick plate from the bottom front of the unit to check underneath for leaks. If the dishwasher is an older model and needs several repairs, consider replacing it. Even a seemingly minor problem like rust on the baskets can cost \$200-300 to replace the offending parts.

Finally, check the drain hose to see if it has an anti-siphon loop or an air-gap device. This anti-siphon loop and/or air-gap device is intended to help keep water and food in the sink or disposer from backing up into the dishwasher tub. The drain hose should be looped up against the bottom of the countertop or connected to an air-gap device before it connects to the disposer or drain pipe under the kitchen sink.

To prevent over-sudsing as well as detergent build-up, run hot water at kitchen sink water fixture before starting the dishwasher. Add a cup of vinegar to the beginning of the wash cycle periodically to freshen the dishwasher. Use only detergent specifically intended for dishwasher use.

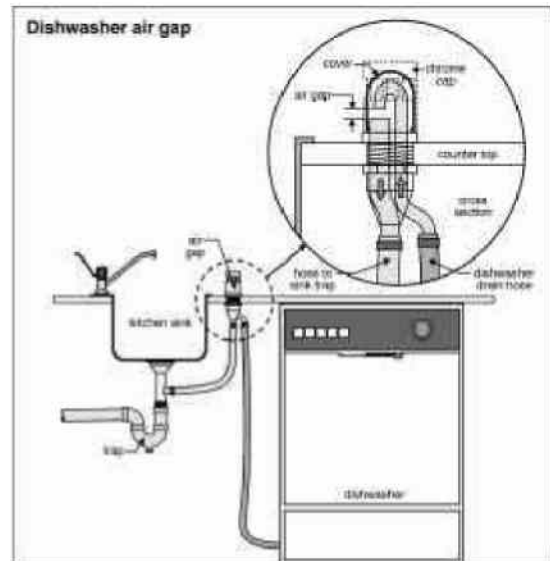

Food Waste Disposer

Remember that the disposer is a vegetarian, especially if sewage disposal is through a septic system. Fats and grease can plug drainpipes and hinder bacteria in a septic system, and large bones or other hard objects can damage or jam the grinding plate. If drain line is long and quite horizontal, fibrous foods or too much garbage at one time can clog the line. Use a strong flow of cold water and keep it running at least 30 seconds after noise of grinding has stopped to flush all food particles through the drainline.

To operate your disposal safely and efficiently, follow directions in the manual with your disposer as to what should not be put through the disposer, and keep all metal and wood objects away from the mouth of the device. If you wash dishes in a sink with a disposer, check to be sure that all small objects are removed from the sudsy water before you drain the sink. Any unusual noises while disposer is operating may mean a foreign object is in the disposer barrel. Turn off disposer immediately and use extreme caution to retrieve the object.

If the rubber splashguard is worn and allows garbage to splash out the top during operation, you may find a replacement splashguard or a strainer for the sink drain at most home centers.

Excessive vibration and noise, or a unit that is rusted out means its time for a new disposer.

Since the dishwasher drains through most disposals, it is a good idea to run your disposal for a few seconds before starting your dishwasher. Avoid using both systems at the same time as this can cause food waste to back up into the dishwasher.

Always run cold water when using your disposal. Leave water running a few moments after turning off disposal to prevent waste build-up in trap. To freshen the disposal, pour a glass of salt water through the system once or twice a week.

Jammed Disposer

NOTE: Be absolutely sure the circuit breaker is off before inserting your hand to remove material when the disposal is stalled. Also be sure it is off before using a wrench or a broomstick.

1. **TURN OFF DISPOSER!** It is very important that the electrical on/off switch is OFF. (Unplug if possible)
2. Turn off the water, if it's still running.
3. Get your Self Service Wrench, it came with your disposer. You can also use a 1/4 inch allen wrench.
4. Look at the bottom of your disposer. Locate the hole in the center of the disposer.
5. Insert the wrench into the hole and work it back and forth in both directions until it turns freely in complete circles. (If disposer is not equipped with a this feature, The same thing can be accomplished by inserting a broom handle into the mouth of the disposal to unlock the blades.
6. Remove whatever was jammed in the disposer by using a pair of tongs to reach down into your disposer. AVOID sticking your hand inside the disposer.
7. Now locate the red reset button on the bottom of the disposer. It should be flush with the bottom of the disposer. If it isn't, press the button in.
8. OK, you should be back in business. Give it a try.
9. No response? Call a plumber.

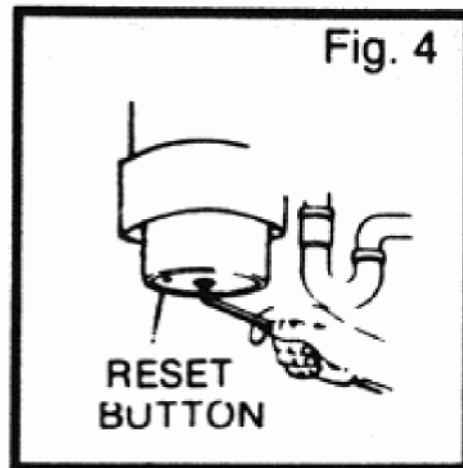

Disposer Do's and Don'ts

Do's:

- Run the disposer each time you put food waste in it. This is particularly advisable in the less expensive models, which are more subject to corrosion from the acids formed by food waste left for a long time.
- Grind food waste with a moderate flow of cold water.

- Grind hard materials such as small bones, fruit pits, etc. A scouring action is created by the particles inside the grind chamber.
- Grind peelings from citrus fruits to freshen up drain smells.
- Flush disposer for cleaning. Allow disposer and cold water to run after grinding or after draining sink of dishwasher. Some detergents are caustic; flushing will pass such material into the drain line without disposer damage.
- Use a disposer cleaner, degreaser, or deodorizer as necessary.

Don'ts:

- Use hot water when grinding food waste. It is OK to drain hot water into the disposer between grinding periods.
- Turn off motor or water until grinding is completed.
- Be alarmed if a brown discoloration appears on the face of the grinding disc. This is normal. It is surface discoloration only and will not affect the life or performance of the disposer.
- Grind large bones or extremely fibrous materials like corn husks, artichokes, etc. to avoid possible drain blockage.
- Do not pour liquid fats down the drain line. (You should solidify liquid fats in empty tin can in the refrigerator, and dispose in the trash.)

Range Hood

Most older range hoods have an exterior vent, while many newer models over electric ranges simply recirculate the air through filters and back into the kitchen. Some cooktops are designed with a downdraft vent on the cooktop surface. All are acceptable. Some of the older exterior vents terminate in the attic, this is an unacceptable practice today. This arrangement blows grease into the attic, creating a fire hazard. We recommend that the vent be extended to the outside.

Test the function of the unit by operating the fan and light. If the light doesn't work, try replacing the bulb. If the unit is very dirty, cleaning may be necessary. Be sure the power supply is shut off before using any cleaning fluids around the fan motor. Range hoods and fans remove grease and moisture from cooking, and so they collect dirt and grease that need to be cleaned regularly. Wash the exposed metal (inside and out) with warm suds solution and rinse. If very greasy, use ammonia and water and rinse. Never use abrasive pads or scouring powders, as they will scratch the finish. Metal filters can be cleaned in the dishwasher. Some hoods have active charcoal filters. The charcoal filters in recirculating range hoods have a life of only ten hours. These filters **cannot** be cleaned. They should be replaced about once a year.

Range / Oven / Cooktops

Illegible or broken control knobs should be replaced. Surface burners and heating elements should be inspected for proper operation on both high and low settings. Any "on" indicator lights should illuminate. Check heating accuracy by placing an oven thermometer in the oven and setting the temperature at 350 degrees. Let the oven heat for at least 25 minutes, then check the thermometer. If it reads within (+) 25 degrees of 350, the oven is operating within normal limits. If not, most oven thermostats can be corrected (sometimes at the control knob).

When broiling food in your oven, keep the door slightly open to prevent smoke from staining the oven surface. Oven surfaces should not be cleaned with abrasive cleaners, as these can mar the surfaces. Usually a mild soap and water will be enough to keep your oven surfaces clean. Cleaning instructions do vary depending on manufacturer, so be sure to check the owner's manual for your particular oven.

New ranges are being installed with an "anti-tip device." This bracket type device at the back of the range prevents tipping if a child climbs onto the oven door to see what's in the soup pot. Most older ranges were installed without this device; consider having one installed if small children are around your house.

For your safety:

Never use your range for warming or heating the room. Your oven and cooktop are not designed to heat your kitchen. Top burners should not be operated without cookware on the grate. Such abuse could result in a fire and damage to your range and will void your warranty.

Do not store or use combustible material, gasoline or other flammable vapor and liquids in the vicinity of this or any other appliance. Explosions or fires could result.

Do not use your oven for storage area. Items stored in the oven can ignite.

Do not let cooking grease or other flammable materials accumulate in or near the range.

Microwave Cooking Equipment

Avoid unnecessary splatters by covering dishes, using wax paper or paper towels when a looser cover is desired. Use an appropriate cover for the cooking process. If oven does not have a removable glass shelf, a plate or paper towel under foods cooked directly on oven floor (as baked potatoes) helps keep it cleaner.

To keep your microwave oven free from grease and soil build-up (wipe up spills at once), wipe it out with a damp cloth after each use. Use liquid window cleaner or a mild detergent and a soft cloth to clean the interior and exterior oven surfaces. Especially clean around edges of the door and door opening, to prevent soil buildup which will prevent door closing tightly. A plastic scrub pad can be used to remove stubborn soils. Do not use abrasive cleaners or steel wool, as they will scratch the interior surface. To keep your oven odor-free, boil one cup of water and several tablespoons of lemon juice in the oven for 5-7 minutes. Wipe out excess moisture after each use.

Tips

- Follow the manufacturer's instruction manual for recommended operating procedures and safety precautions.
- Do not operate the oven with door open.
- Do not use the oven for storage.
- Do not operate the oven as a timer or without food.
- Don't use the microwave for deep-frying, canning, or heating baby bottles. These applications don't allow adequate temperature control for safe results.
- Stay near the oven when microwaving popcorn, heat buildup can cause a fire. Time heating per instructions but lean toward the shorter time (some ovens can scorch popcorn in two minutes).
- Don't dry or disinfect clothing or other articles in the microwave because of the risk of fire.
- Use only microwave-safe utensils. Hot food melts some plastics, such as margarine tubs, causing migration of package constituents. It's a good idea to use glass for fatty foods, which get particularly hot, though not all glass and ceramics are microwave-safe.
- Here's a quick test for glass: Microwave the empty container for one minute. It's unsafe for the microwave if it's warm; it's OK for re-heating if it's lukewarm; and it's OK for actual cooking if it's cool.
- Don't use an oven if an object is caught in the door or if the door doesn't close firmly or is otherwise damaged. If you have an older model oven with a soft mesh door gasket. Check for deterioration, which would require servicing.
- Don't operate an empty oven if the introduction manual warns against this. In some ovens the magnetron tube can be damaged by unabsorbed energy.
- If there are signs of rusting inside the oven, have the oven repaired.
- Be sure children who use the microwave can do so safely.
- There previously was concern that electromagnetic emissions from microwave ovens could interfere with heart pacemakers. Modern pacemakers are shielded against such interference, but some older models may still be adversely affected by proximity to a microwave oven. If in doubt, check with your doctor.
- An area of a food where there is increased moisture will heat more quickly than other areas. So, when heating up a jellyroll, for instance, it's a good idea to let the food stand after cooking for a minute or two until the heat disperses from the high moisture jelly to the low moisture and passed throughout. To promote uniform cooking, recipes for microwave ovens usually include directions such as turn the food midway through cooking and cover and let stand after cooking.
- As a rule, it's not good to use metal pans made for conventional ovens or aluminum foil because reflected microwaves cause uneven cooking and could even damage the oven. However, some new metal cookware is

specially configured for use in microwave ovens. These pans are safe, provided instructions for use are carefully followed.

- Some oven models have a protector on the magnetron tube to allow use of a small amount of metal, such as meat skewers or strips of foil over chicken wings and legs. The instructions that come with each microwave oven tell what kinds of containers to use and how to test for suitability for use.

Bathroom Exhaust Fans and Heaters

Bathroom Exhaust Fans

Before servicing or cleaning any mechanical exhaust vent, you should disconnect to the power source at the service panel. To clean the fan cover, fan blades and interior housing of the exhaust fan you can use a vacuum cleaner and then use a damp wash cloth.

Under current building standards all interior mechanical exhaust vents should be vented to the exterior of the house and not into the attic area. If there is a bathroom in the home that does not have a working window in place, the bathroom should be equipped with a mechanical exhaust vent that vents to the exterior of the house.

Bathroom Heaters

In many older homes you will find a gas space heater mount in the wall of the bathroom. These gas space heaters are not vented to the exterior of the structure and are considered unsafe to use under current building standards. We strongly recommend that these gas heaters are removed and the gas supply properly disconnected.

Garage Door Operators

For a garage door opener to operate properly, it is important that the garage door be in good condition and functioning properly. Examine garage doors and the surrounding framing for evidence of wood rot and physical damage. Check doors for proper operation and balance. Release the automatic operator from the door in the down position. The door or should easily open to its full height and close smoothly without crashing to the floor. A balanced door will stay in place when opened to a height of five or six feet. Rollers and hinges should not be loose and should operate smoothly. Regular servicing of rollers and tracks will help keep them working well. Since springs are under great tension and can cause serious injury or damage if mishandled, the adjustment of door springs is best left to a qualified contractor.

Reattach the automatic operator and test the safety reversing mechanism. Place a rolled up Sunday newspaper or a 2X4-inch board flat on the floor under the center brace in the garage door, and operate the door. A properly adjusted door will automatically reopen when striking the paper or board, without excessive pressure or jerking. (Note: lightweight metal doors can be damaged if the reverse mechanism does not function properly during this test). Adjustments at the operator motor can correct most malfunctions. (Refer to illustration on page 33)

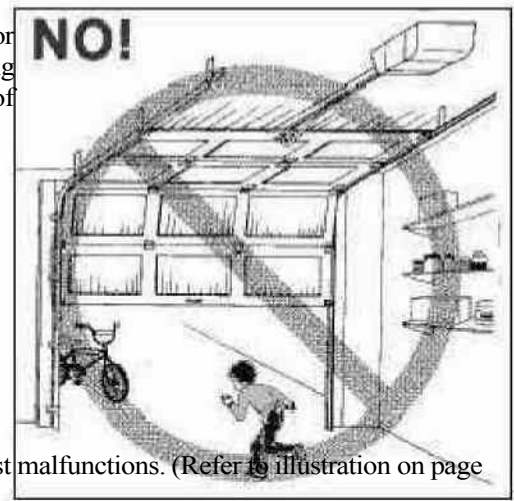

Door operators manufactured after 1993 will also have optical sensors installed near the floor on each side of the door opening. These sensors should be installed within 6 to 12 inches of the garage floor. If the beam between the sensors is broken while the door is closing, it should reverse directions and open. If the optical sensors are not properly aligned, the door will not function as intended. Do not attempt to circumvent these safety features. They are designed to minimize the risk of a large, heavy, moving object. (Refer to illustration on page 33)

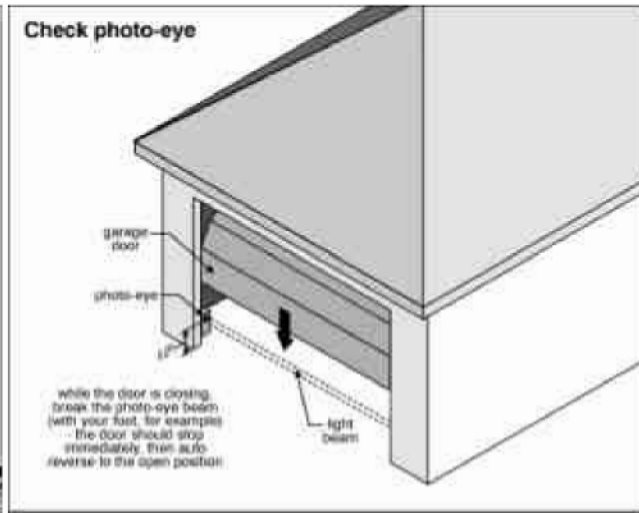
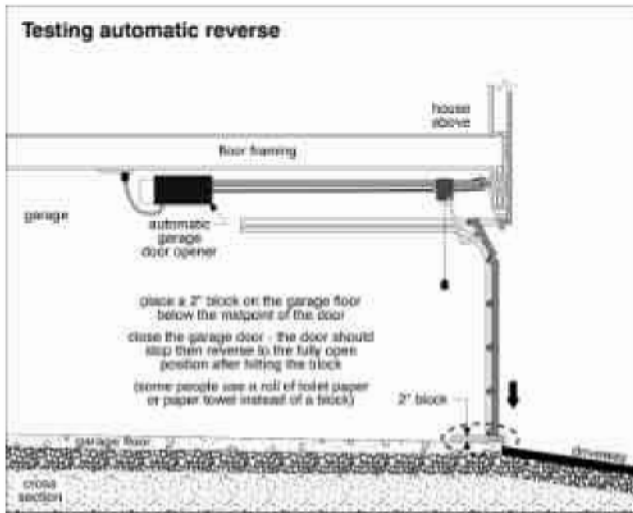

Dryer Vents

Every three to four months, check your dryer vent for excessive lint buildup and clean the vent. Cleaning the dryer's lint screen before each use prevents lint buildup and saves energy. If you experience problems with your dryer ventilation system, you should have the problem corrected as necessary. Do not disconnect the dryer vent and vent it into the garage area, attic area or crawl space area. *This is a known health and fire hazard.*

Under current building standards all dryer vents should vent to the exterior of the house.

OPTIONAL SYSTEMS

Lawn Sprinklers

Lawn sprinkler systems require regular maintenance. Once a month, run through the stations with the manual controls, checking each station for broken or misdirected sprinkler heads, broken pipes and surface leaks. A properly adjusted system will result in less water in the street and greener grass.

All systems are required to have backflow protection to protect drinking water supplies from contamination. Requirements vary from city to city, but it is important to know where your backflow protection is located and how to shut off the water supply for repairs or freeze protection. Check these components regularly for operation and water leaks. A qualified lawn irrigation contractor can help you better understand your system and learn how to maintain it.

Swimming Pools and Equipment

Pools vary in size and shapes. They vary from simple to complex. If you are buying a pre-existing home, it is *very important* to consult with the current homeowner on the pool's builder, current maintenance program and any previous repairs that have been made to the pool and its components. Consult with the current homeowner about the operation of the pool valves and any special features the pool may have. If the current homeowner was using a pool maintenance company, you should contact that company for all maintenance records that they may have on file. You should have the pool and equipment thoroughly inspected and evaluated by a qualified pool technician and make any repairs that are recommended.

Proper care and maintenance is very important. Here are some maintenance tips to follow.

Once a week:

- **Skim the surface.** The water must be skimmed of floating debris, such as insects, grass clippings and leaves. Use a surface skimmer or a leaf baggie for this purpose.
- **Clean out the skimmer.** Remove the pool skimmer lid and the skimmer basket. Clean out the skimmer and basket using a garden hose with a high-pressure nozzle or your finger over the end of the hose.
- **Vacuum the swimming pool twice a month.**
- **Check the pressure gauge on the filter.** If the indicated pressure on the gauge is 8lbs. to 10 lbs. above starting or clean pressure, the filter must be backwashed or cleaned. Also bleed trapped air from the filter using the air-relief valve. Follow the manufacturer's directions for cleaning, backwashing and filter bleeding.
- **Clean out the strainer.** Shut off the pump. Then remove the lid from the pump strainer basket. Remove basket and clean out the debris using a high-pressure nozzle or your finger over the end of the hose.
- **Test the total alkalinity.** The proper range for total alkalinity is 80 to 120 ppm. (parts per million)
- **Test for pH.** The proper range for pH is between 7.4 and 7.6. Be sure the total alkalinity is in the proper range before adjusting the pH.
- **Test for chlorine.** Check the water for chlorine residual. Make sure there is at least 1 ppm of residual chlorine. The proper range for free chlorine is 1.0 to 3.0 ppm.

Just remember that swimming pools are a lot of fun to have but can be dangerous if they are not properly maintained. Pools are also inviting to the small children that can not swim. If the pool does not have proper perimeter barriers, you should consider correction measures immediately.

Here is some safety tips to follow:

- NEVER LEAVE A CHILD UNSUPERVISED NEAR A POOL.
- INSTRUCT BABYSITTERS ABOUT POTENTIAL HAZARDS TO YOUNG CHILDREN IN AND AROUND SWIMMING POOLS AND THE NEED FOR CONSTANT SUPERVISION.
- COMPLETELY FENCE THE POOL.
- INSTALL SELF LOCKING AND SELF-CLOSING GATES. POSITION LATCHES OUT OF REACH OF YOUNG CHILDREN.
- DO NOT CONSIDER YOUNG CHILDREN "DROWN PROOF" BECAUSE THEY HAVE HAD SWIMMING LESSONS.
- DO NOT USE FLOTATION DEVICES AS A SUBSTITUTE FOR SUPERVISION.
- NEVER USE A POOL WITH ITS POOL COVER PARTIALLY IN PLACE. REMOVE A POOL COVER COMPLETELY.
- PLACE TABLES AND CHAIRS WELL AWAY FROM THE POOL FENCE TO PREVENT CHILDREN FROM CLIMBING INTO THE POOL AREA.
- KEEP TOYS AWAY FROM THE POOL AREA BECAUSE A YOUNG CHILD PLAYING WITH THE TOYS COULD ACCIDENTALLY FALL IN THE WATER.
- HAVE A POOLSIDE TELEPHONE WITH EMERGENCY NUMBERS TAPED TO IT.
- LEARN CARDIOPULMONARY RESUSCITATION (CPR).
- KEEP RESCUE EQUIPMENT BY THE POOL

Gas Lines

Natural gas is odorless, for your safety an odorant is added to the gas. If you smell gas or what you believe to be gas, open windows, *do not touch electrical switches* extinguish any open flames, and immediately call the gas supplier.

Homes or structure that have gas service should check for gas leaks annually. Small gas leaks can occur and be undetected for long periods of time. In under ventilated or poorly ventilated homes, this could pose a hazard. An annual inspection of the gas valve shutoffs and gas connectors should also be made. You should never use un-vented gas stoves, ranges or heaters.

Radon In The Home

Radon (Rn) is a colorless, odorless, radioactive gas. Radon is produced when trace amounts of uranium and radium in the soil or rocks decay. The radon gas will then also decay into radioactive solid particles, called radon daughters or radon progenitors. Some of the short-lived radon daughters attach themselves to small particles in the air, which can be inhaled deep into the lungs. The radon daughters may then damage dividing lung cells, possibly resulting in lung cancer. Radon gas is thought to be responsible for 5,000 to 20,000 lung cancer deaths per year in the United States.

The major sources of radon are: soil that contains radon-releasing material; water and natural gas that has passed through underground areas containing radon; solar-heating systems that use radon-emitting rocks to store heat; granite rock; and uranium or phosphate mine tailings.

Out-of-doors, radon poses little threat to our health because it is in such a low concentration. Indoors, however, radon can become more concentrated because of the lack of ventilation in homes combined with exhaust fans that draw air. Radon gas can seep into a house through dirt floors, cracks in concrete floors and walls, floor drains, sump pumps, and joints. Radon gas can also accumulate in private wells and be released into the home when water is used. This is normally not a problem for large community water supplies. The level of radon that can build up indoors depends upon the amount of radon in the source material and the rate at which it is removed from the home by ventilation. Homes tested throughout the U.S. show a wide range of radon concentrations.

These quick, inexpensive steps advised by the EPA can be taken to help lower your risks from radon exposure:

- Stop smoking and discourage smoking in your home; it may increase the risk of radon exposure.
- Spend less time in areas with higher concentrations of radon, such as the basement.
- Whenever practical, increase the airflow into and through your house, especially in the basement.
- If you home has a crawl space beneath, keep the vents on all sides of the house fully open all year.

There are two commercially-available radon detectors, the charcoal canister and the alpha-track detector. Both of these are exposed to the air in your home for a specific time period and sent to a laboratory for analysis. For additional information about radon, contact the American Lung Association.

Termites

Termites are important wood-destroying pests in Texas. The word "Termite" comes from the Latin word *Termites*, meaning wood-worm. Most North Texas termites are subterranean (under ground forms) and must have contact with moist ground in which to build their nests. The food of subterranean termites is largely cellulose and comes from many sources. In fact, termites will eat all materials made from plants or cellulose-containing plant products.

Subterranean termites are most abundant in moist, warm soils containing plenty of food. Such conditions are found beneath poorly ventilated buildings, scraps of lumber, stumps covered by fill, grape roots (usually in old abandoned vineyards), or any part of a wood structure close to the ground, such as porches, foundation sills, or steps.

Termites travel from nests in the soil through a brownish, cork-like tube to their food supply. When, through control measures, the contact between the nest in the ground and the wood upon which they feed is broken, termites die.

Termites feed on the inside of sills, studding, floors, sub-floors, casings, baseboards, and other wood structures. They tunnel these parts of a house leaving in many cases only thin shelves of the harder part of the wood. Inside the galleries, the wood is rough, tooth-notched and occasionally coated with yellowish-corky, muddy material, which is often black-specked.

Termites rarely appear on the surface except when they are winged and swarming, usually in April or May following a warm rain. However, they can occur in summer and fall. If the wood upon which they are feeding is broken through, they immediately seal the opening with a brownish, cork-like material. Termites do not leave sawdust as do powder-post beetle and carpenter ants. Also, there are no small openings to the outside of the wood as in the case of powder-post beetles.

Termite Control

Homeowners should be constantly on the lookout for termites. An easy way to locate termite damage in sills, floor joists, and studding is to plunge an ice pick or screwdriver into the wood. If the wood is solid, the ice pick or screwdriver probably will not go very far into it. On the other hand, if the pick enters easily, you should inspect all wood carefully for termites. Also, look for mud tubes from the soil, across the foundation to the wood. These can be seen in crawl spaces or basements - across foundations or in block voids.

When you find insect-damaged wood, be absolutely sure the insects are still present and, if so, whether or not they are termites. In any case, do not panic! Determine the extent of the damage by probing with an ice pick or screwdriver as mentioned above.

When a termite infestation is present, you have 2 choices:

1. Rely on the services of a qualified experienced termite control operator or:
2. Attempt to control them yourself. The first choice, in most cases, is preferred. "Do it yourself" termite control is seldom satisfactorily achieved.

While termite control can be fairly expensive, the cost is usually justified in the special equipment such as concrete drills, pressure applicators, etc., technical knowledge and experience, large volumes of chemical and time required to properly apply the treatments. Special attention should be given to termite-proofing chemicals and structures built into buildings on "floating" concrete slabs. If the slab cracks, even as little as 1/32 of an inch, the termites are afforded a well protected, hidden, direct route to and from their food source.

If this is your first encounter with termites, take your time in selecting a qualified and experienced termite control company. Termites work slowly and the chances of the building falling down in an additional 2 to 3 weeks or even months are indeed extremely slim. A logical way to select a company is to:

1. Choose several companies (2 or more) and establish their credibility through the Better Business Bureau or Chamber of Commerce.
2. Obtain both damage and cost estimates from several companies.
3. Obtain references from the companies and check the references as thoroughly as possible.
4. Compare your notes on the various companies and make your final decision. Above all, do not be panicked into an immediate "off the cuff" treatment. The time spent in following the above procedure is time well spent and necessary when engaging any type of service.

For a complete listing of suggested control options for all home, yard and garden insect pests contact your local Extension Service, found under local government in the phone book.

Moisture Problems in the Home

Condensation can be a problem in both winter and summer. Three conditions in the home increase the chances that condensation will occur. The first of these is a relatively recent phenomenon. Many homeowners have added insulation to cut heat loss and heat gain, while others have caulked and placed weatherstripping around windows and doors to reduce the infiltration of cold air into their homes. The same practices that trap heat in the home also trap high levels of moisture.

A second common condition contributing to moisture problems in Texas homes is the existence of cool surfaces with which interior moisture vapor naturally comes in contact. In less energy-efficient homes, certain locations are prime candidates for condensation problems because they commonly have cool surfaces. These include poorly weatherized and insulated windows (in winter), poorly insulated exterior walls and ceilings (winter), masonry or concrete surfaces (summer), toilet tanks (summer) and cold water pipes (summer).

A third condition contributing to household condensation problems is excessively high humidity levels in the air within the home. The normal indoor humidity range in winter is 15 to 50 percent. In the summer, the humidity range may be higher because of the higher outdoor humidity levels we sometimes experience then.

High Humidity Level Problems

The first step to be taken in attempting to control condensation problems is simply to reduce the level of humidity in the inside air.

During the winter, the humidity level you will want to attempt to achieve in your home will depend on the outside temperature. As outside temperatures drop, you need to lower inside relative humidity levels to minimize condensation.

Monitor the interior surfaces of double-pane windows during winter. If running water (condensation) is apparent on them, the interior relative humidity level is too high and should be lowered.

Levels to achieve in summer are somewhat more arbitrary---they depend mainly on how uncomfortable you are in high humidity conditions.

Summer Problems

During the summer, one of the major functions of an air conditioner, in addition to cooling warm interior air, is removing humidity from the home. A second alternative available to lower summertime humidity levels is to purchase and operate a dehumidifier. If humidity levels remain high in winter, you may need to run it then, too. Though both air conditioners and dehumidifiers are effective solutions to excessive moisture problems, they are relatively expensive to buy and costly to operate. Expect increases in your electricity bills during the months you use them.

Houses on Crawl Spaces

In homes built on crawl spaces, evaporation of moisture from the earth is a major source of household humidity. The high levels of humidity in crawl spaces can be a problem in both summer and winter. Foul odors in the home or crawl space, mold and mildew growth in the interior of the home (especially in closets) and growth of fungi in the crawl space itself are signs of the problem. Covering the crawl space ground with a vapor retarder (polyethylene or heavy plastic sheets available at lumberyards) is crucial in preventing moisture problems in crawl space homes.

In addition to a vapor retarder covering the ground, crawl spaces should be provided with adequate natural ventilation to facilitate air movement throughout the space. If a vapor retarder is present in the crawl space, 1 square foot of free vent area is required for every 300 square feet of crawl space ground area. Without a vapor retarder present, 1 square foot of free vent area is required for every 150 square feet of crawl space ground area. Most crawl space vents include louvers and/or screens to prevent the entry of insects and small animals. These coverings slow air circulation and cut down on the vent's effectiveness. Thus, you will need to double the amount of ventilation needed in most cases to compensate for this reduction. Locate vents near corners and across from one another to facilitate air movement through the crawl space.

Attic Ventilation

Adequate natural ventilation is important in the attics of homes as well. If a vapor retarder is not present in the ceiling to slow migration of moisture from the home's interior into the attic, attics require 1 square foot of free vent area for each 150 square feet of attic area. An exception occurs when the attic vents are located in a high/low configuration (i.e., half of the vent area in the eave/soffit area and the other half in the roof ridge area). In that case, 1 square foot for

each 300 square feet is adequate. If a vapor retarder is present in the ceiling, attics require 1 square foot of free vent area for each 300 square feet of attic area.

Causes of mildew

Mildew is a thin, usually black, sometimes white, growth produced on many kinds of surfaces by molds. Molds are simple plants belonging to the group known as fungi. Though molds are always present in the air, those that cause mildew need moisture and certain temperatures in order to grow. They commonly develop in humid summer weather, especially in houses that are closed. They grow fastest at temperatures between 75 F. and 85 F. Sunlight helps kill mildew.

These molds grow on anything from which they can get enough food. In homes they develop most often on cotton, linen, rayon, silk, wool, leather, wood, and paper. Many synthetic fibers are resistant to mildew.

Molds that cause mildew flourish wherever it is damp, warm, poorly lighted, and/or where air is not circulated--in cellars, crawl spaces or houses without basements, and clothing closets; on draperies and rugs in basement recreation rooms, on shower curtains, and on damp clothes rolled up for ironing. These molds are also likely in a newly built house because of moisture in the building materials.

Preventing Mildew

1. Keep Things Clean

Keep closets, dresser drawers, basements--any place where mildew is likely to grow--as clean as possible. Soil on dirty articles can supply enough food for mildew to start growing when moisture and temperature are right. Greasy films, such as those that form on kitchen walls, also contain many nutrients for mildew-causing molds.

2. Get Rid of Dampness

Dampness in a crawl space or basement, or any other part of the structure, is often caused by condensation of moisture from humid air onto cooler surfaces. Excessive moisture may indicate that repairs or additional insulation are needed. Replace cracked or defective mortar. Some crawl spaces or basements are continually wet from water leaking through crevices in the wall. Make sure outside drainage is adequate.

3. Control Moisture

For waterproofing concrete and other masonry walls above ground, apply two coats of cement paint, tinted with mineral coloring if desired. Waterproofed coatings to seal absorbent brick and other outside surfaces may be needed.

Spread a layer of moisture-barrier material over the soil in crawl spaces under houses. You can use heavy roofing paper or polyethylene plastic film. Good ventilation is important. If possible, do not enclose the crawl space. In extreme cases, a fan or blower may be needed to move the humid air from under the building.

Cooking, laundering, and bathing may add 2 gallons or more of water a day to the house. If circulation is not adequate use some type of exhaust fan that exhausts to the exterior of the structure. If your clothes dryer is equipped with a vent, have it exhausted to the outside to remove moist air.

4. Dry the Air

Cool air holds less moisture than warm air. Properly installed air-conditioning systems remove moisture from the air by taking up warm air, cooling it (which removes the moisture) and circulating the cool dry air back into the room. In rooms that are not air-conditioned--especially the crawl space or basements--mechanical dehumidifiers are useful. A humidistat can be attached to the unit to control the humidity. Mechanical dehumidifiers, however, can add heat to a room. When using air-conditioners or dehumidifiers, keep windows and doors closed.

5. Heat

Get rid of dampness by heating the house for a short time, then open doors and windows to let out the moisture-laden air. An exhaust fan that terminates to the exterior of the structure may be used to force it out. Using an electric light continuously (60- to 100-watt bulb) can dry air in closets and other small areas. The heat will prevent mildew if the space is not too large. **PRECAUTION:** Be sure to place the light bulb far enough from clothing and other flammables to avoid the danger of fire.

Chemicals that absorb moisture--may be used to absorb moisture from the air. Follow directions on the label exactly.

6. Circulate the Air

When the air outside is drier than that inside, ventilation allows the dry air to enter, take up excess moisture, and then be carried outside. When natural breezes are not sufficient, you can use electric fans placed in a window, set in a wall, or ducted to the attic to move air from the house.

Poorly ventilated closets get damp and musty during continued wet weather, and articles stored in them are apt to mildew. Try to improve the air circulation by opening the closet doors. In addition, hang the clothes loosely so that air can circulate around them. Dry all wet clothing (including clothes wet from rain or perspiration) before putting it in the closet.

7. Get Rid of Musty Odors

Get rid of musty odors as soon as possible to prevent further mold growth. Usually musty odors disappear if the area is well heated and dried. If the odors remain, the following treatment may be necessary.

On cement floors and on tiled walls and floors in bathrooms, get rid of mustiness by scrubbing with a diluted solution of sodium hypochlorite or other chlorine bleach available in grocery stores. Use one-half to 1 cup of liquid household bleach to a gallon of water. Rinse with clear water and wipe as dry as possible. Keep windows open until walls and floors are thoroughly dry. **PRECAUTION:** Work quickly and carefully on plastic and asphalt tile to avoid spotting the surface.